

Product Manual

Progressive
Divider

JPQ1
JPQ1_FKM

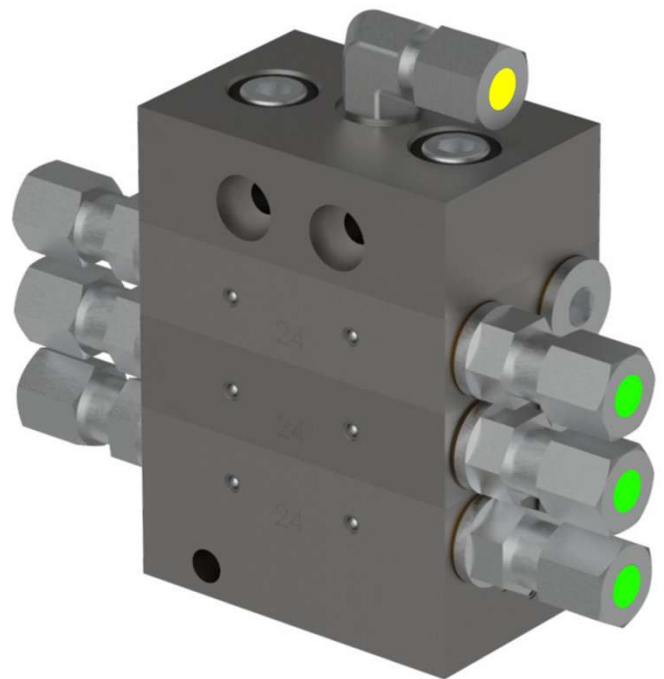

Index

Legal disclosure	3-4
Safety instructions	4
Delivery, returns and storage	5
Commissioning	6
Lubricant	7
Overview	8
Working principle	9
Assembly and components	10-18
Combination principle	19-21
Divider monitoring sensor	22-23
Divider accessories	24-25
Order key	26
Special version FKM (Viton seals)	27-28
Order key FKM	29
Troubleshooting	30

Legal disclosure

Manufacturer

Lubmann GmbH
 Add: Kleiner Johannes 21, 91257, Pegnitz, Germany
 E-Mail: info@lubmann-gmbh.de
 Website: www.lubmann-gmbh.de

Training courses

In order to provide a maximum of safety and economic viability, Lubmann GmbH carries out detailed training courses. It is recommended that the training courses are attended. For more information, please contact Lubmann GmbH.

Copyright

© Copyright Lubmann GmbH All rights reserved.

Warranty and extent of warranty

Inappropriate intervention will rule out your warranty claim!

Warranty regarding operational safety, reliability and performance of the lubricating pump is only accepted by the manufacturer under the following conditions:

- Assembly, connection, setting, maintenance and repair are carried out by authorized and specialized staff.
- The limits stipulated in the technical data must never be exceeded.
- Only original components or components approved by the manufacturer may be used for repair and maintenance work.

All guarantees and warranties expire for damages to central lubrication systems that are caused by operation with improper lubricants (e.g., piston wear, piston jamming, plugins, embrittled sealings).

Lubmann does not assume liability on damages caused by lubricants, even if these lubricants have been tested and released by laboratory tests, as damages caused by lubricants (e.g., by expired or improper stored lubricants, batch variations etc.) can not be retraced to their root cause in retrospect.

Service address

Kleiner Johannes 21, 91257, Pegnitz, Germany
 Tel.: +49 9241 80 89 87 00

Disclaimer

The manufacturer shall not be held responsible for damages caused by:

- Non appropriate use faulty assembly, operation, setting, maintenance, repair or accidents
- Use of inappropriate lubricants
- Improper or late response to malfunctions
- Unauthorized modifications of the product
- Intent or negligence
- Use of non-original Lubmann spare parts
- Faulty planning or layout of the centralized lubrication system

Liability for loss or damage resulting from the use of our products is limited to the maximum purchase price. Liability for consequential damages of whatever kind is excluded.

Safety instructions

General information

Any safety-related faults must be eliminated without delay.

Below, please find fundamental instructions to be complied with, regarding assembly, operation and maintenance. The mechanical and the competent specialists / staff of the operating company must read the Operating Instructions on all accounts prior to starting assembly and commissioning. Moreover, the Operating Instructions must permanently be available on site.

Not only the safety instructions included under this item, but also the specific safety instructions appearing in other parts of this manual must be complied with.

General risk information

All system components have been designed with operational safety and accident prevention in mind, in accordance with the applicable regulations for the design of technical work equipment.

It should be noted, however, that the use of these systems may present certain risks to the user of third parties, as well as to the technical equipment itself. Therefore, it is of the utmost importance that the system is only used for its intended purpose and in compliance with the relevant safety regulations and operating instructions

Explanation of symbols



Safety instructions which, if not complied with, may endanger persons, are marked specifically with the general hazard symbol:



This heading is used if inaccurate compliance or non-compliance with the Operating Instructions or specified work procedures etc. may result in damage



Points out Special Information

Delivery, Returns and Storage

Delivery

After receipt of the shipment, check the shipment for damage and completeness according to the shipping documents. Immediately report any transport damages to the forwarding agent. Keep the packaging material until any discrepancies are resolved. During in-house transport ensure safe handling.

Returns

Clean all parts and pack them properly (i.e., following the regulations of the recipient country) before returning them. Protect the product against mechanical influences such as impacts. There are no restrictions for land, sea or air transport.

Storage

Lubmann products are subject to the following storage conditions:

dry, dust- and vibration-free in closed premises
no corrosive, aggressive materials at the place of storage (e. g. UV rays, ozone)
protected against pests and animals (insects, rodents, etc.)
possibly in the original product packaging
shielded from nearby sources of heat and coldness
in case of high temperature fluctuations or high humidity take adequate measures (e. g. heater) to prevent the formation of condensation water

Storage conditions for parts filled with lubricant

The conditions mentioned in the following will have to be adhered to when storing products filled with lubricant,

Storage period of up to 6 months

The filled products can be used without having to take further measures.



Step for Storage period from 6 to 18 months - Divider

1. Remove all connection lines and closure screws
2. Connect the pump which has been filled with new lubrication grease suitable for the application purpose to the divider
3. Let the pump run until new lubricant leaks from the divider
4. Remove leaked lubricant
5. Reinstall closure screws and connection lines

Commissioning

Connect the pump properly to the designated connections. Check the device for functionality and the presence of safety features.

Ensure that all warning labels are present, undamaged, and clearly visible. If this not the case, they must be replaced immediately.

Deviating from Intended Use is strictly Prohibited

Please adhere to the technical specifications provided in the manual and do not exceed the specified limits. Improper use is strictly prohibited. Only use lubricants intended for this purpose. Make sure to use the product exclusively within its designated area of use.

Accompanying Documents

In addition to this manual, the following documents must be considered by the respective target audience:

- 1) Operational instructions and release regulations

If applicable:

- 2) Safety data sheet for the lubricant used
- 3) Project documentation
- 4) Supplementary information regarding special configurations of the pump. These can be found in the specific system documentation.
- 5) Instructions for additional components for the assembly of the central lubrication system.

Lubricant

The system has been designed for commercially available multi-purpose greases of NLGI class 2 for operation in summer and winter.

- Use greases with high-pressure additives (EP greases).
- Only use greases of the same saponification type.
- Lubricants containing solid contents must not be used (lubricants like graphite or MoS₂ on request).
- Observe the vehicle manufacturer's specifications, when you select the lubricant.



Hazards to environment cause by lubricants

The lubricants which are recommended by the manufacturer of your vehicle, system or machine correspond in their composition to the common safety regulations. Mineral oils and greases are generally hazardous to ground water and their storage, processing and transport requires special precautions.

Inadmissible methods of operation



Operational security of the plant is only guaranteed if it is operated in accordance with the operating instructions. The limit values stated in the technical data must not be exceeded under any circumstances.

Transport and storage of the divider

The dividers of the series JPQ1 are packed commercially, according to the regulations of the recipient country and to the wish of the customer. There are no limitations with respect to land, air or sea transport. Store in a dry place at a temperature of -5° C to +35° C.

Overview

The progressive piston dividers are divider devices with a hydraulic sequence control, the pistons of which are regulated by the supplied lubricant in a way that the lubricant inevitably and successively escapes at the individual outlets. In the case of malfunction during the flow of lubricant, e.g. plugging of lubricating line or lubricating points, the divider will block up.

The divider sensor are used for the monitoring of the distributors. In the case of manually operated pumps a virtually insurmountable counter pressure occurs during the blockage. In the case of automatic pumps such as e.g., the electrical pump ALP81 or ALPB the lubricant escapes at the safety valve.

The progressive JPQ1 dividers are manufactured in a variable chip-type structure, which offers the advantage that the divider can be extended or shortened at random according to the amount of lubrication points. Due to this chip-type structure, there is also the possibility of constructing an overall progressive divider from individual distributor disks with different outputs per piston stroke.

The difference in output per piston stroke is created by different piston diameters. To get the correct functioning of a progressive divider a minimum of three pistons, i.e., a minimum of three output elements is a must.

Technical data:

Operating pressure - Inlet: max. 300 bar
 Temperature range: -35°C to +70°C
 Lubricant: Oil-fluid grease-Grease up to NLGI-Kl.-2
 In- / Outlet Thread: M10x1

Number of elements:

Min.: JPQ1-3/6 (3 output elements)
 Max.: JPQ1-9/18 (9 output elements)

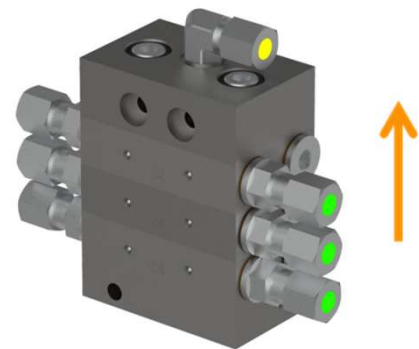

Attention : By installing the dividers, please make sure that the divider can always be mounted vertically like the arrow direction above.



Element	Delivery Quantity (mm ³ /Stroke)		Piston-Ø mm
	Per outlet	Per element	
ME-08	80	160	4.0
ME-16	160	320	5.7
ME-24	240	480	7.0
ME-32	320	640	8.0
EE-08	80	160	4.0
EE-16	160	320	5.7
EE-24	240 </td <td>480</td> <td>7.0</td>	480	7.0
EE 32	320	640	8.0

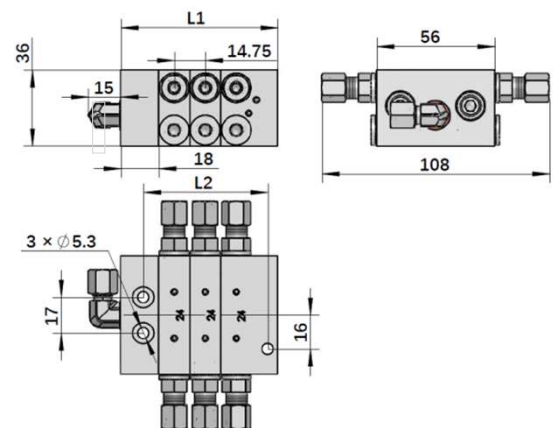

Outlets	6	8	10	12	14	16	18
L1 (mm)	74.5	89.3	104.0	118.8	133.5	148.3	163.5
L2 (mm)	59.0	73.8	88.5	103.3	118.0	132.8	147.6

Working Principle

The progressive divider consists of the individual components start element SE (without piston), 2-7 middle element ME and end element EE, all of which are assembled in distributor blocks using tension rods (hexagon socket screws) with lock washers. The individual elements are sealed with O-rings between each other.

The lubricant flows via the inlet of the distributor through all distributor disks to the piston A. The piston (A) is shifted to the left and the lubricant is pressed from the left pressure range of the delivery piston to the outlet ① (Dia. 9.1).

After that, the proportioning pistons B and C are progressively shifted and the lubricant is primed to the outlets ② (Dia. 9.2) and ③ (Dia. 9.3).

After the piston C has been shifted, the lubricant is directed to the left side of the delivery piston A (Dia. 9.4) and primed from the right pressure range of the delivery piston to the outlet ④.

Subsequently, the delivery pistons B and C are shifted and lubricant is pressed to the outlets ⑤ (Dia. 9.5) and ⑥ (Dia. 9.6).

After the delivery piston has been shifted, the lubricant is once more directed to the right side of the delivery piston (Dia. 9.1) and a new cycle of the progressive divider is initiated. The described function is repeated as long as lubricant is fed to the progressive divider.

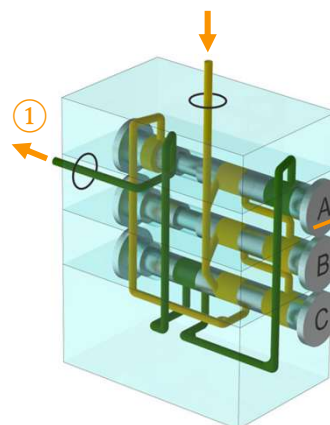

Dia. 9.1 A

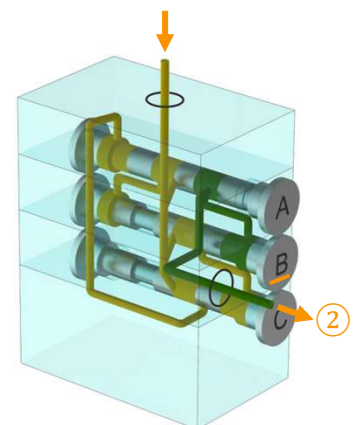

Dia. 9.2 B

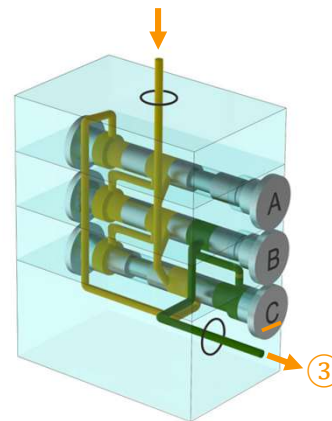

Dia. 9.3 C

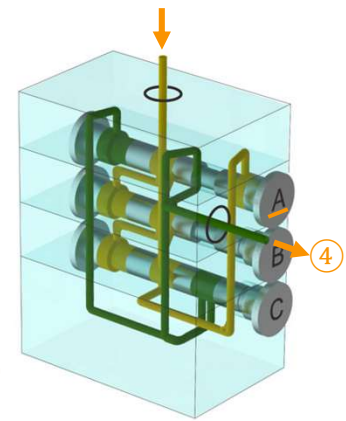

Dia. 9.4 D

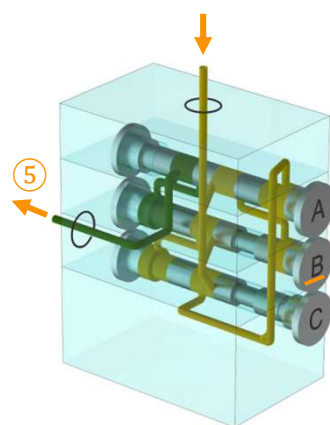

Dia. 9.5 E

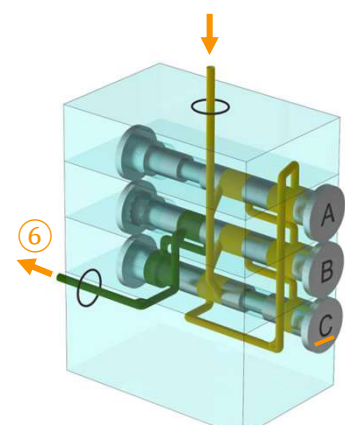

Dia. 9.6 F

Assembly and Components

The divider is made of a series of at least 4 elements:

- 1x start element,
- 2x middle elements,
- 1x end element.



Always start with the largest delivery quantity of the distributor chip behind the start element!

With components e.g., bridge with outlet or blind plug, the divider can be built with multiple configurations to match the grease requests of the greasing points.

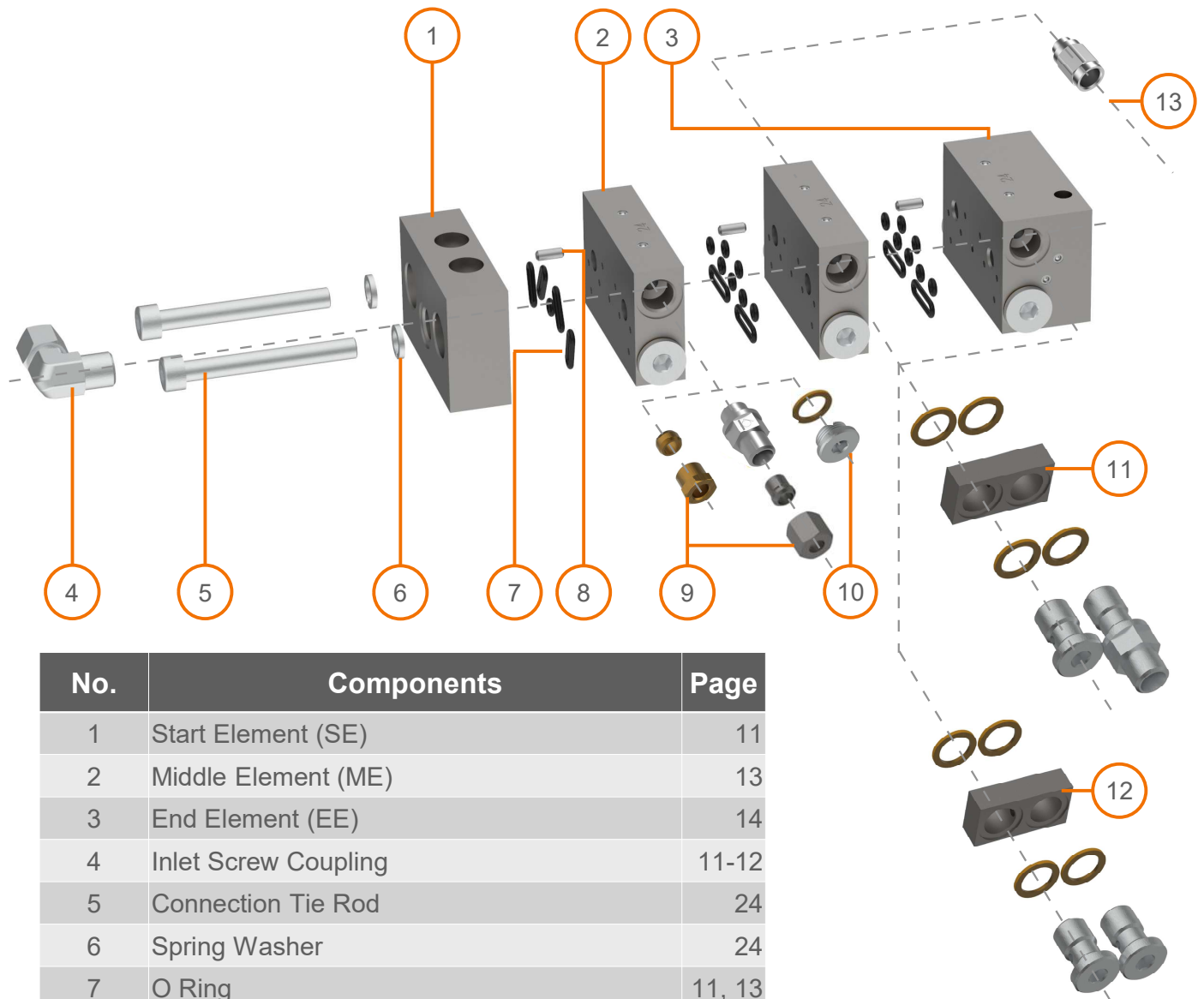

No.	Components	Page
1	Start Element (SE)	11
2	Middle Element (ME)	13
3	End Element (EE)	14
4	Inlet Screw Coupling	11-12
5	Connection Tie Rod	24
6	Spring Washer	24
7	O Ring	11, 13
8	Cylinder Pin between Elements	11, 13
9	Outlet Screw Coupling	15-17
10	Outlet Blind Plug	17
11	Bridge with Outlet	18
12	Bridge without Outlet	18
13	Divider Monitoring Sensor	22-23

Dia. 10.1
Divider Components

Start Element (SE)

Start element is the element without outlets (*Dia. 11.1*).
Every divider must have a start element.

Description	Part No.	
Start element, SE, incl. O-Ring Set & Pin		2020520330
Spare Parts	Qty. per Set	
O-Ring-7,5x1,5-SH85-NBR	4	3021000239
O-Ring-2,5x1,5-SH85-NBR	1	3024000240
Cylinder pin-JPQ1-D3x8-A2	1	3040100050

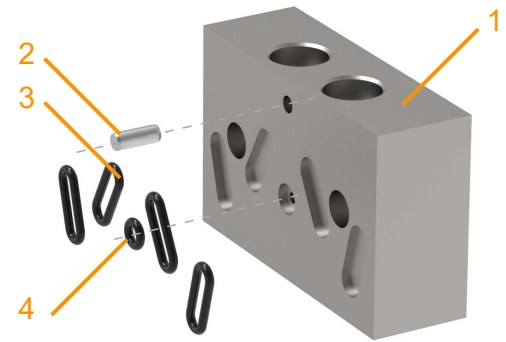

- 1 Start Element Body
- 2 Cylinder pin
- 3 O-Ring
- 4 O-Ring

Dia. 11.1 Start Element

Inlet Screw Couplings

The JPQ1 progressive divider can be used as either a main divider or a secondary divider.

When used as a main divider, the pump and main divider are connected by a high-pressure hose and hose studs with outer diameter 6mm or 8mm. When used as a secondary divider, the main divider and secondary dividers are normally connected by a high-pressure hose and hose studs with outer diameter 6mm.

All screw couplings with M10x1k threads can be directly used for the inlet connection of the JPQ1 divider. All screw couplings with M10x1 threads can be used together with a sealing ring (or ED sealed) for the input connection.

WE Elbow Inlet Screw Couplings WE (*Dia. 11.2*)

Description	Part No.	
WE-D6LL-M10x1k-ST-ZnNi		9900147
WE-D8LL-M10x1k-ST-ZnNi		9900149
Spare Parts 1		
Cutting ring-single edge-SRE-D6LL-ST-ZnNi		9900209
Cutting ring-single enge-SRE-D8LL-ST-ZnNi		9900211
Spare Parts 2		
Union nut-ÜM-D6LL-ST-ZiNi		9900199
Union nut-ÜM-D8LL-ST-ZiNi		9900202

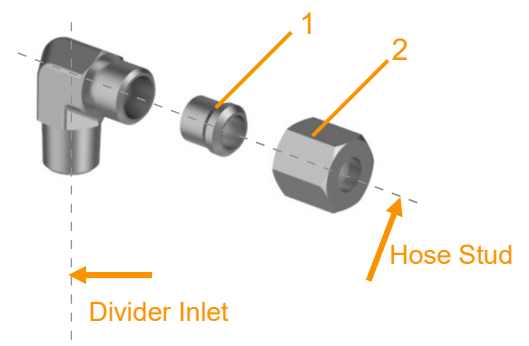

- 1 Cutting ring-single edge
- 2 Union nut

*Dia. 11.2
Elbow Inlet Screw Coupling*

Inlet Screw Couplings

GE Straight Inlet Screw Couplings (Dia. 12.1)

Description	Part No.
GE-D6LL-M10x1k-ST-ZnNi *	9900111
GE-D8LL-M10x1k-ST-ZnNi *	9900112
GE-D6LL-M10x1 (SW14-ED)-ST-ZnNi	3050100890
GE-D8LL-M10x1-(ED)-ST-ZnNi	3050104830
Spare Parts 1	
Cutting ring-single edge-SRE-D6LL-ST-ZnNi	9900209
Cutting ring-single edge-SRE-D8LL-ST-ZnNi	9900211
Spare Parts 2	
Union nut-ÜM-D6LL-ST-ZiNi	9900199
Union nut-ÜM-D8LL-ST-ZiNi	9900202

* Part with "*" is standard part in our JPQ1 order key.

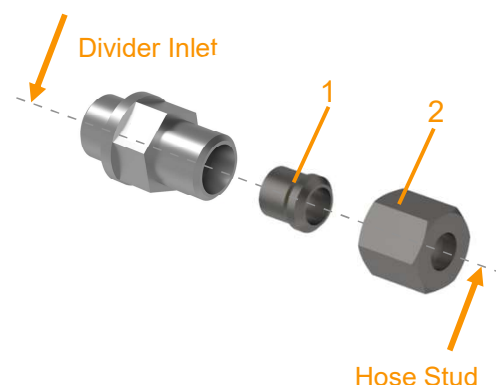

- 1 Cutting ring-single edge
- 2 Union nut

Dia. 12.1
Straight Inlet Screw Coupling

EWE Elbow Screw Coupling adjustable and

WS Swivel Inlet Screw Couplings (Dia. 12.2 and Dia. 12.3)

Description	Part No.
EWE-D6LL-M10x1-(ED)-ST-ZnNi Dia. 12.2	3050100620
EWE-D8LL-M10x1-(ED)-ST-ZnNi Dia. 12.2	3050105150
WS-D6LL-M10x1-(DK)-ST-ZnNi Dia. 12.3	9900323
WS-D8LL-M10x1-(DK)-ST-ZnNi Dia. 12.3	9900324
Spare Parts 1	
Cutting ring-single edge-SRE-D6LL-ST-ZnNi	9900209
Cutting ring-single edge-SRE-D8LL-ST-ZnNi	9900211
Spare Parts 2	
Union nut-ÜM-D6LL-ST-ZiNi	9900199
Union nut-ÜM-D8LL-ST-ZiNi	9900202

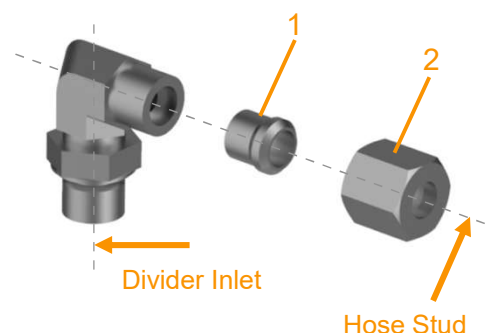

- 1 Cutting ring-single edge
- 2 Union nut

Dia. 12.2 Swivel Inlet Screw Coupling

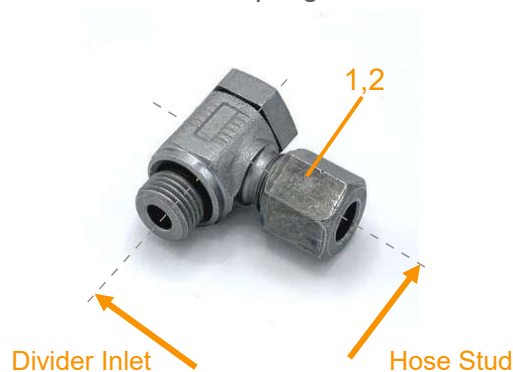

- 1 Cutting ring-single edge
- 2 Union nut

Dia. 12.3
Swivel Inlet Screw Coupling

Middle Element (ME)

The middle element of JPQ1 divider has four output flow rates.

On the front side of the JPQ1 ME, the Pos. **A** as in *Dia. 13.1* shows the flow rate for the single element:

08 = 80 mm³ per outlet / stroke
 16 or 16-S = 160 mm³ per outlet / stroke
 24 or 24-S = 240 mm³ per outlet / stroke
 32 or 32-S = 320 mm³ per outlet / stroke

The middle elements ME-16-S, ME-24-S and ME-32-S in *Dia. 13.2* have the possibility to be installed with a divider monitoring sensor right or left side of the elements.



The Kit-divider monitoring sensor must be ordered separately!

Technical data and part no. for divider monitoring sensor please check on page 22.

Description	Possibility to be installed with a divider monitoring sensor	With in- and outlets screw couplings	Part No.
ME-08-N	No	No	2020520290
ME-16-N	No	No	2020520300
ME-24-N	No	No	2020520310
ME-32-N	No	No	2020520320
ME-16-S	Yes	No	2111000219
ME-24-S	Yes	No	2111000220
ME-32-S	Yes	No	2111000221

All middle elements in the table above include cylinder pin, o ring sealing set, sealing steel ball and sealing screw.

Spare Parts – Middle elements	Qty. per Set	Part No.
Cylinder pin-JPQ1-D3x8-A2	1	3040100050
O-Ring-2,5x1,5-SH85-NBR	7	3024000240
O-Ring-11,5x1,5-SH85-NBR	2	3024000234
Sealing screw for divider outlet separation-M4-ST	1	3040102550
Sealing steel ball for divider outlet separation-D3-ST	1	3049000450

The sealing screw and steel ball can only be taken out from the right-side outlet of the elements (Dia. 13.1).

For more details of the function of sealing screw set please check page 19-21.

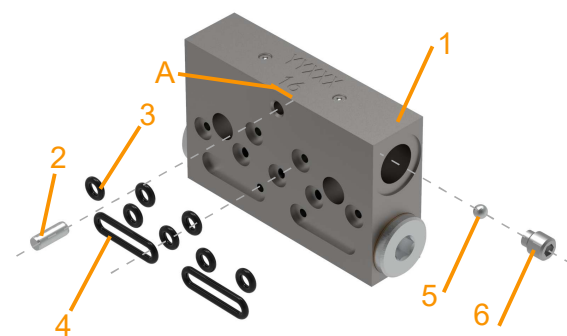

- 1 Middle element
- 2 Cylinder pin
- 3 O-Ring
- 4 O-Ring
- 5 Sealing steel ball
- 6 Sealing screw

*Dia. 13.1
(ME) Middle Element*

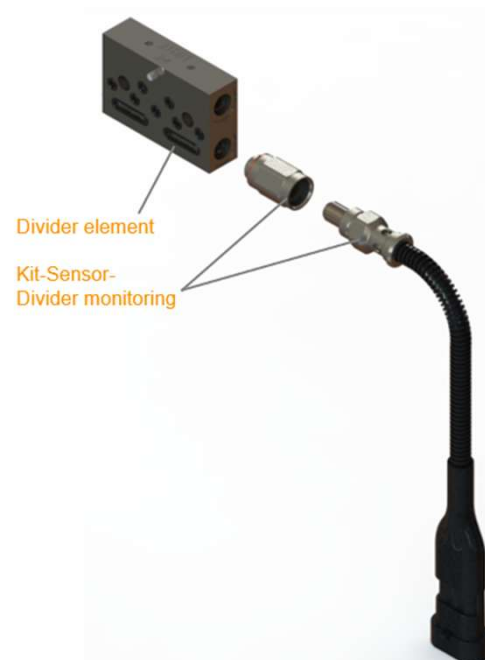

*Dia. 13.2
Example for (ME) Middle element
with Kit-Sensor divider monitoring
on the right side*

End Element (EE)

The end element (EE) of JPQ1 divider has four output flow rates.

On the front side of the JPQ1 EE, the Pos. **A** as in *Dia. 14.1* shows the flow rate for the single element:

08 = 80 mm³ per outlet / stroke
 16 or 16-S = 160 mm³ per outlet / stroke
 24 or 24-S = 240 mm³ per outlet / stroke
 32 or 32-S = 320 mm³ per outlet / stroke

The end elements EE-16-S, EE-24-S and EE-32-S in *Dia. 14.2* have the possibility to be installed with a divider monitoring sensor right or left side of the element.



The Kit-divider monitoring sensor must be ordered separately!
Technical data and part no. for divider monitoring sensor please check on page 22.

Description	Possibility to be installed with a divider monitoring sensor	With in- and outlets screw couplings	Part No.
EE-08-N	No	No	2020520260
EE-16-N	No	No	2020520270
EE-24-N	No	No	2020520280
EE-32-N	No	No	2020520520
EE-16-S	Yes	No	2111000222
EE-24-S	Yes	No	2111000223
EE-32-S	Yes	No	2111000224

All end elements in the table above include cylinder pin, sealing steel ball and sealing screw.

Spare Parts – End elements	Qty. per Set	Part No.
Sealing screw for divider outlet separation-M4-ST	1	3040102550
Sealing steel ball for divider outlet separation-D3-ST*	1	3049000450

* The sealing screw and steel ball can only be taken out from the right-side outlet of the elements (*Dia. 14.1*).
 For more details of the function of sealing screw set please check page 19-21.

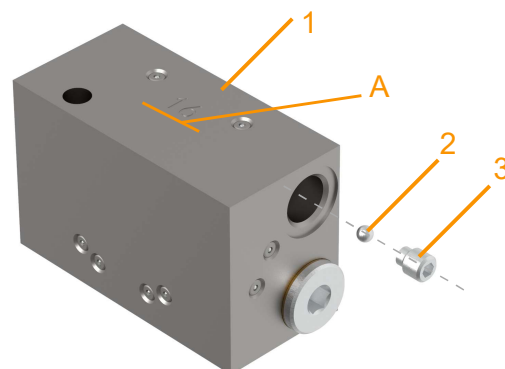

- 1 End Element Body
- 2 Sealing Steel Ball
- 3 Sealing Screw

Dia. 14.1
(EE) End Element

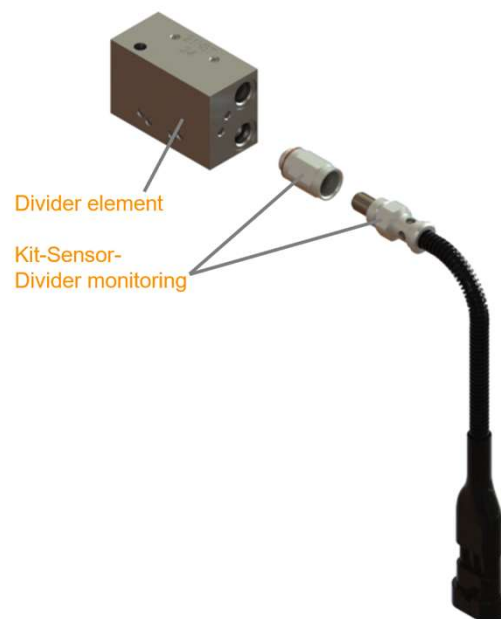

Dia. 14.2
Example for (EE) End element with Kit-Sensor-Divider monitoring on the right side

Outlet Screw Couplings

The JPQ1 progressive divider can be used as either a main divider or a secondary divider.

From the main divider to the secondary divider, a screw coupling with non return valve is mainly used as the outlet fitting of the main divider for the connection with a high pressure hose and hose stud with outer diameter 6mm. From the secondary divider to the greasing points, a screw coupling without non return valve is mainly used as the outlet fitting of the secondary divider for the connection with a polyamide pipe with diameter 6x1.5mm or steel pipe with a diameter 6x1mm.

For construction machinery application like excavators, wheel loaders, please use non return valves for all divider outlets due to the high back pressure from the greasing points.



All screw couplings (including double cone socket union, non return valve and coupling without non return valve) with M10x1k threads can be directly used for the inlet connection of the JPQ1 divider. All screw couplings with M10x1 threads can be used together with a sealing ring (or ED sealed) for the input connection.

Type of Couplings	Main Divider Outlet with High Pressure Hose with Hose Stud D6mm	Secondary Divider Outlet with High Pressure Hose with Hose Stud D6mm	Secondary Divider Outlet with PA Hose or Steel Pipe D6mm
RDGE	✗	✗	✓
RGE	✓	✓	✗
GE	✗	✓	✗
ÜS	✗	✗	✓
GES	✗	✗	✓

- RDGE Non-Return valve with double cone ring
- RGE Non-Return valve
- GE Straight screw couplings
- ÜS Union screw with double cone ring
- GES Straight screw coupling-push in

RDGE Non-Return valves with double cone ring (Dia. 15.1)

Description	Part No.
RDGE-M10x1-M10x1-with sealing cone-ST-ZnNi-wo. unit nut and double cone ring	9901653
Spare Parts 1	
Double cone ring-DKR-D6L/LL-MS	9900226
Spare Parts 2	
Union screw-ÜS-D6LL-M10x1-ST-ZnNi	9900223

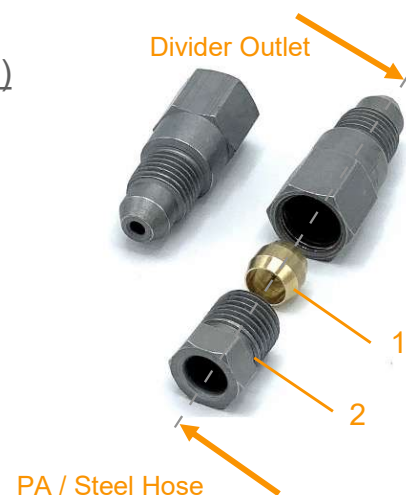

- 1 Double cone ring
- 2 Union screw

With RDGE no sealing ring (or ED-sealing) needs to be used!

Dia. 15.1 RDGE Non-Return Valve with Double Cone ring

Outlet Screw Couplings

RGE Non return valve (Dia. 16.1 and Dia. 16.2)

Description	Part No.
RGE-6LL-M10x1-ST-ZnNi (Dia. 16.1)*	9901652
RGE-6LL-M10x1-ST-ZnNi (Dia. 16.2)	2020120150
Spare Parts	
Cutting ring-single edge-SRE-D6LL-ST-ZnNi	9900209
Spare Parts 2	
Union nut-ÜM-D6LL-ST-ZiNi	9900199
Spare Parts 3	
Sealing ring-DR-DIN7603 A-10x14x1-Cu	3010401930

* Part with "*" is standard part in our JPQ1 order key.

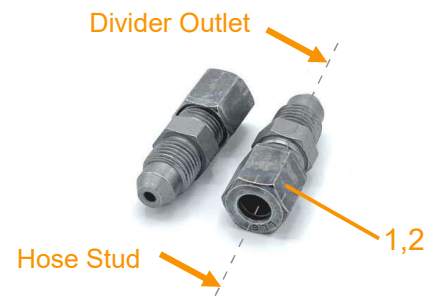

- 1 Cutting ring-single edge
- 2 Union nut

Dia. 16.1
Non-Return Valve with sealing cone

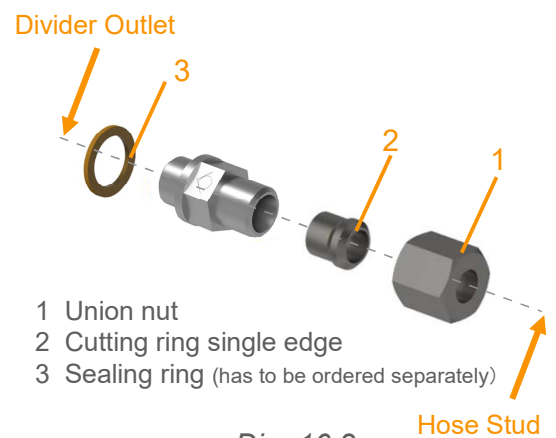

- 1 Union nut
- 2 Cutting ring single edge
- 3 Sealing ring (has to be ordered separately)

Dia. 16.2
Non-Return Valve with Sealing ring

GE Straight screw coupling (Dia. 16.3)

Description	Part No.
GE-D6LL-M10x1k-ST-ZnNi *	9900111
GE-D6LL-M10x1-(SW12-ED)-ST-ZnNi	2020420350
Spare Parts 1	
Union nut-ÜM-D6LL-ST-ZiNi	9900199
Spare Parts 2	
Cutting ring-single edge-SRE-D6LL-ST-ZnNi	9900209

* Part with "*" is standard part in our JPQ1 order key.

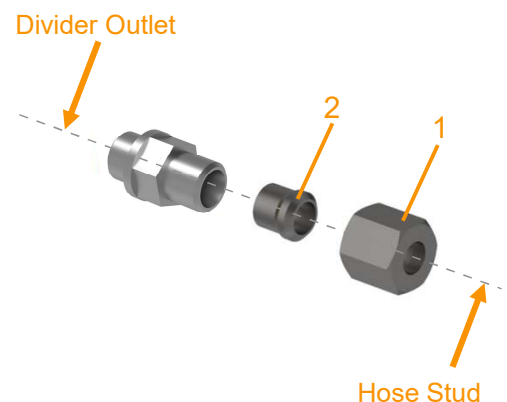

- 1 Union nut
- 2 Cutting ring-single edge

Dia. 16.3
Straight screw coupling

Outlet Screw Couplings

ÜS Union screw with double cone ring (Dia. 17.1)

Description	Part No.
Union screw-ÜS-D6LL-M10x1-ST-ZnNi (1 in Dia. 17.1)	9900223
Double cone ring-DKR-D6L/LL-MS (2 in Dia. 17.1)	9900226

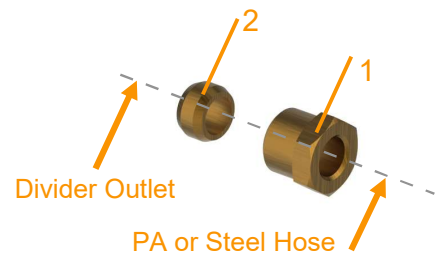

- 1 Union screw
- 2 Double cone ring

*Dia. 17.1
Union screw with Double cone ring*

GES Straight screw coupling-push-in (Dia. 17.2)

Description	Part No.
GES-D6-M10x1k-150 bar-MS-Ni	9900233

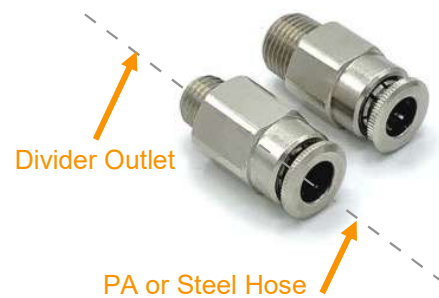

*Dia. 17.2
Straight screw coupling-push in*

Screw plug for divider outlet

The function of the blind plug of the JPQ1 divider outlet is to achieve a double flow rate by direct blinding one of the 2 sides on a same middle or end element.

To achieve this function, before the blinding, the sealing screw and sealing screw ball of the element must be taken out in advance, otherwise the divider will be blocked.

** More details regarding the working principle please check on page 9.*

Description	Part No.
Screw plug-DIN908-M10x1-ST-ZnNi	3010401940
Sealing ring-DR-DIN7603 A-10x14x1-Cu	3010401930

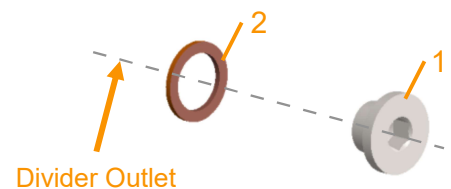

- 1 Screw plug
- 2 Sealing ring

*Dia. 17.3
Screw plug for divider outlet*

Bridge with / without Outlet

The function of the bridge with or without outlet of the JPQ1 divider is to achieve a combined flow rate by external blinding the outlets on the same side of 2 adjacent elements.

The sealing screw and sealing ball of the element can be taken out or kept depends on the configuration.

** More details regarding the working principle please check on page 19-21.*

Description	Part No.
Kit-Divider bridge-JPQ1-without outlet-without non return valve	2090110380

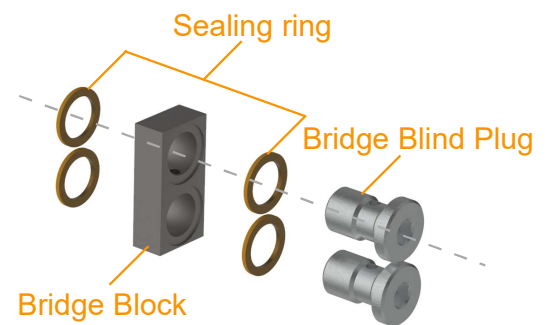

*Dia. 18.1
Bridge without Outlet*

Description	Part No.
Kit-Divider bridge-JPQ1-with one outlet-cutting ring-single edge-with non return valve	2090100160

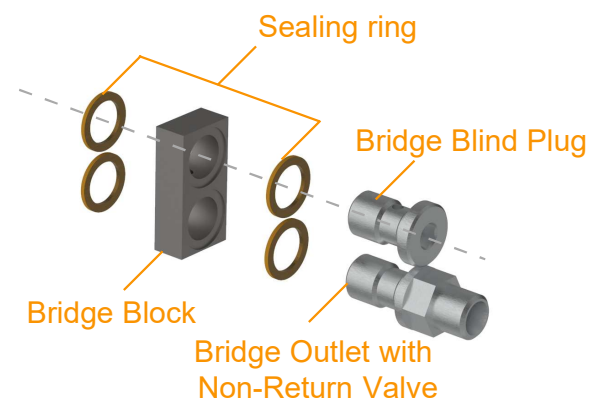

*Dia. 18.2
Bridge with Outlet and Non-Return Valve*

Extra OB Bridge Kits

Description	Part No.
Kit-Divider bridge-JPQ1-without outlet-with non return valve-with screw plug	2020520550
Kit-Divider bridge-JPQ1-with one outlet-for double cone-with non return valve	2020520560
Kit-Divider bridge-JPQ1-with one outlet-for double cone-without non return valve	2020520570
Kit-Divider bridge-JPQ1-with one outlet-cutting ring-single edge-without non return valve	2020520580

Element Combination Principle

In order to meet the volume demand of the different greasing points under various application environment, even if the JPQ1 divider provides 4 different flow rate single element (8/16/24/32), sometimes it is still necessary to combine the outlets of the divider internally or externally to achieve more possibilities of the flow rate combination.

With the help of e.g. element internal bridge* - sealing screw and sealing ball, external bridge** - OB-0 and OB-1, JPQ1 divider can achieve these possibilities.

* Internal Bridge - the divider element bridged left and right

** External Bridge - the divider elements bridged up and down

Single Element without Combination

Dia. 19.1 shows the divider middle element with 2 separate outlets which have the same output flow rates. The grease channel has been separated by a sealing ball and sealing screw.

Description	Part No.
Outlet Screw Coupling	Page 15-17
Sealing screw for divider outlet separation-M4-ST	3040102550
Sealing steel ball for divider outlet separation-D3-ST	3049000450

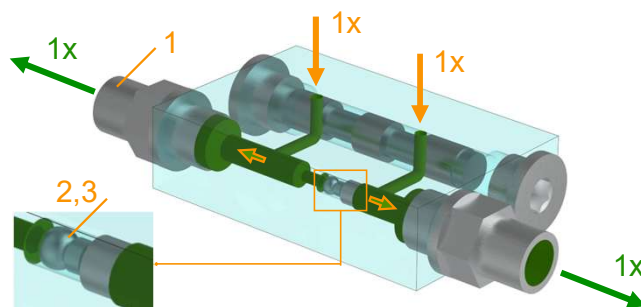

- 1 Straight screw coupling
- 2 Sealing steel ball
- 3 Sealing screw

Dia. 19.1
Single Element without Combination

Single Element with Combination

Dia. 19.2 shows the divider middle element with 1 outlet (either on left side or on right side), which the other of the element has been locked by an outlet blind plug and removing the sealing steel ball and sealing screw. The flow rate of the left outlet is doubled.

Attention: In this case, the sealing steel ball and sealing screw must be removed, otherwise the divider blocks!

Description	Part No.
Outlet Screw Coupling	Page 15-17
Screw plug-DIN908-M10x1-ST-ZnNi	3010401940
Sealing ring-DR-DIN7603 A-10x14x1-Cu	3010401930

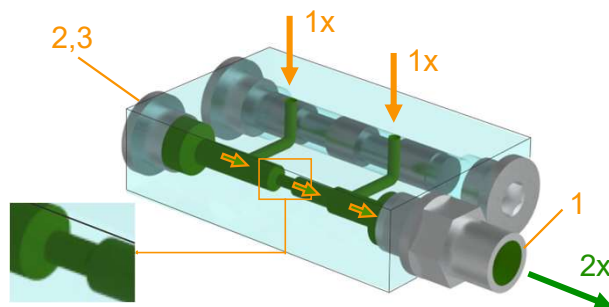

- 1 Straight screw coupling
- 2 Screw plug
- 3 Sealing ring

Dia. 19.2
Single Element with Combination

Element Combination Principle

Combination A with OB-0 (1 Outlet)

Dia. 20.1 shows the 2 divider elements are connected by an outlet bridge OB-0 on left side. In the mean time, both element's middle sealing screws and steel balls are removed. In this case, all **four** outlets are bridged together on the right.

Description	Part No.
Straight screw couplings	Page 15-17
Kit-Divider bridge-JPQ1-without outlet-without non return valve	2090110380
Screw plug-DIN908-M10x1-ST-ZnNi	3010401940
Sealing ring-DR-DIN7603 A-10x14x1-Cu	3010401930

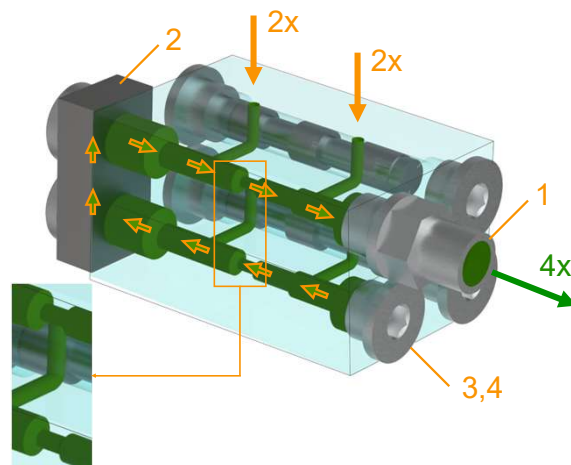

- 1 Straight screw Coupling
- 2 Kit-Divider bridge without outlet
- 3 Screw plug
- 4 Sealing ring

Dia. 20.1
Two Divider Elements with OB-0
Combination A

Combination B with OB-0 (2 Outlets)

Dia. 20.2 shows the 2 divider elements are connected by an outlet bridge OB-0 on left side. In the mean time, 1 of the 2 elements' middle sealing screw and steel ball is removed. In this case, the grease channel is separated by the sealing screw and steel ball, only **three** outlets are bridged with each other.

Description	Part No.
Straight screw couplings	Page 15-17
Kit-Divider bridge-JPQ1-without outlet-without non return valve	2090110380
Sealing screw for divider outlet separation-M4-ST	3040102550
Sealing steel ball for divider outlet separation-D3-ST	3049000450

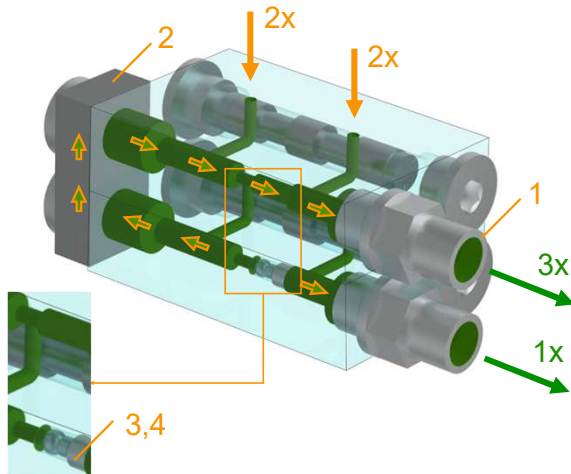

- 1 Straight screw coupling
- 2 Kit-Divider bridge without outlet
- 3 Sealing screw
- 4 Sealing steel ball

Dia. 20.2
Two Divider Elements with OB-0
Combination B

Element Combination Principle

Combination A with OB-1 (1 Outlet)

Dia. 21.1 shows the 2 divider elements are connected by an outlet bridge OB-1 on left side. In the mean time, both element's middle sealing screws and steel balls are removed. In this case, all 4 outlets are bridged with each other.

Combination B with OB-1 (2 Outlets)

Dia. 21.2 shows the 2 divider elements are connected by an outlet bridge on left side. In the mean time, 1 of the 2 elements' middle sealing screw and steel ball is removed. In this case, the grease channel is separated in 2 ways by the sealing screw and steel ball, only 3 outlets are bridged with each other.

Combination C with OB-1 (3 Outlets)

Dia. 21.3 shows the 2 divider elements are connected by an outlet bridge on left side. In the mean time, both elements' middle sealing screws and steel balls keep in position. In this case, the grease channel is separated in 2 ways and only 2 outlets on left side are bridged.

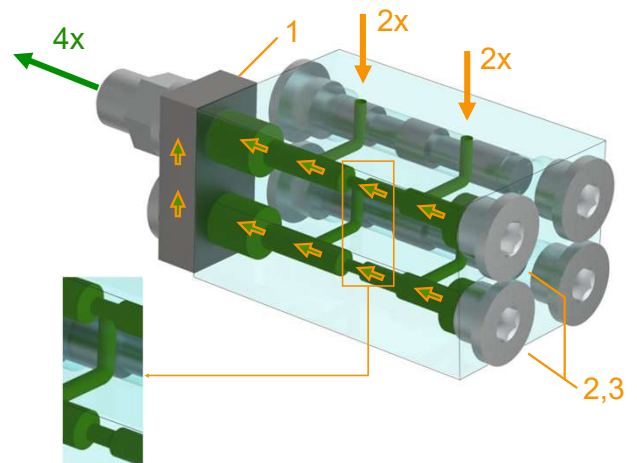

Dia. 21.1

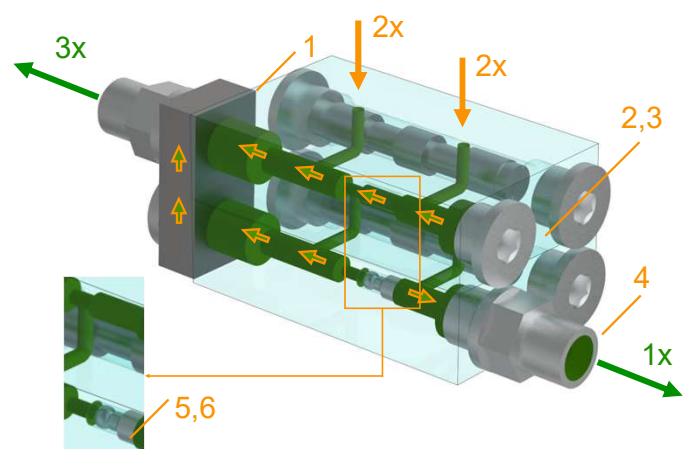

Dia. 21.2

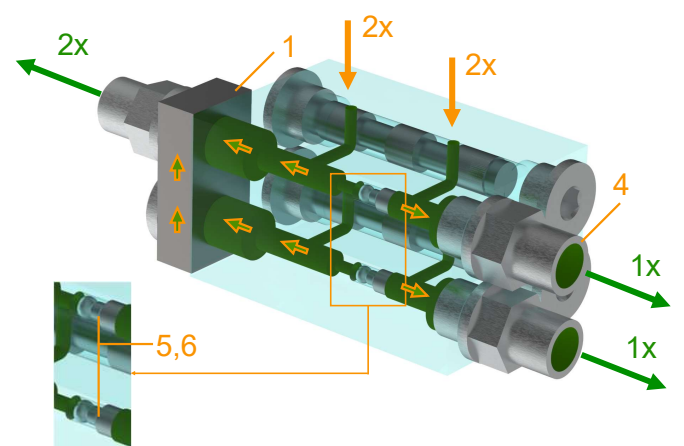

Dia. 21.3

- 1 Bridge with Outlet
- 2 Screw plug
- 3 Sealing ring
- 4 Straight screw coupling
- 5 Sealing screw
- 6 Sealing steel ball

Description	Part No.
Straight screw couplings	Page 15-17
Kit-Divider bridge-JPQ1-with one outlet-cutting ring-single edge-with non return valve	2090100160
Screw plug-DIN908-M10x1-ST-ZnNi	3010401940
Sealing ring-DR-DIN7603 A-10x14x1-Cu	3010401930
Sealing screw for divider outlet separation-M4-ST	3040102550
Sealing steel ball for divider outlet separation-D3-ST	3049000450

Divider Monitoring

The progressive divider JPQ1 can be monitored by means of a sensor.

In the middle and end element of the S series, magnetic pins are installed in the pistons. Here, a sensor can be installed on the right or left as required.

The sensor is damped by the piston movement.

The sensor sends signals to the control unit of the grease lubrication pump. If the divider blocks, the control unit of the grease lubrication pump recognises that no signals are being sent by the sensor.



Only ME-16-S/24-S/32-S and EE-16-S/24-S/32-S are available for a divider monitoring sensor. Check part numbers on page 13-14.

We offer two different types of sensors:

PNP (Standard for ALP-Modells): Output function NO (+)
NPN (for external Controller only): Output function NO (-)

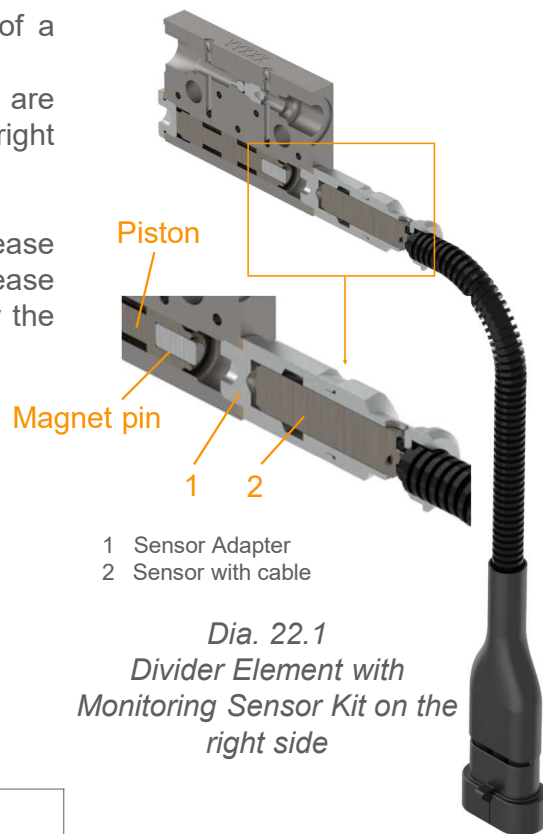

Dia. 22.1
 Divider Element with Monitoring Sensor Kit on the right side

	Part No.
Kit-sensor-divider monitoring-JPQ1-M10x1-AMP_M_3P-PNP	2020420490 (Standard)
Kit-sensor-divider monitoring-JPQ1-M10x1-AMP_M_3P-NPN	2020420480

Technical Data:	
Working principle:	magnetic
Connection with divider:	M10x1
Connection with cable (sensor):	AMP_M_3P
Switching Distance:	max. 20 mm
Operating current Ie:	200 mA
Operating Voltage ub:	10 to 30 VDC
Temperature Range:	-25 °C to +85 °C
Function Display:	LED
Housing material:	Stainless steel
Protection Type:	IP 67
Approval/Confirmity:	cULus / CE / WEEE / EAC

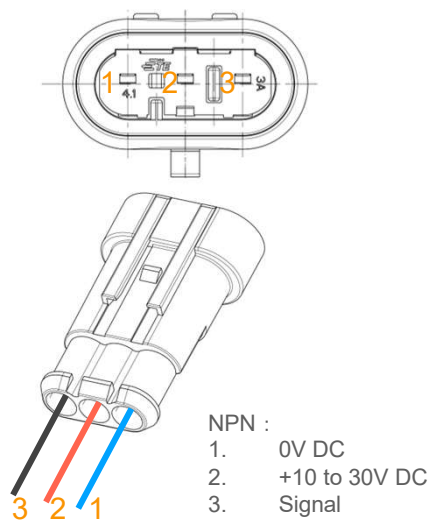

Dia. 22.2 Divider Monitoring Sensor Wiring Connection



Dia. 22.3
 Adapter fit for divider monitoring sensor-M10x1 - M12x1-SW12-L25 (Part No. 3050103160)

For the Part No. of Kit-divider monitoring sensor, the sensor connector and sensor with cable are included (Dia. 22.1).



The connecting cable between sensor and pump are NOT included.

More information for cables please check on the next page.

Divider Monitoring – Connecting cable



Depends on the various application, the sensor cable need be ordered separately as following description.

	Cable kit-divider monitoring With BD plug	Cable kit-divider monitoring with HSC plug
Length: 5,0 m	2110012410	2110010539
Length: 7,5 m	2110012409	2110002734
Plug at divider side:	TE - AMP Super Seal 1.5 SRS. 3P plug connector (IEC 529 and ISO 20653)	
Plug at pump side:	RD24 Series 693	Appliance plug GDM 3011 J (DIN EN 175 301-803-A)

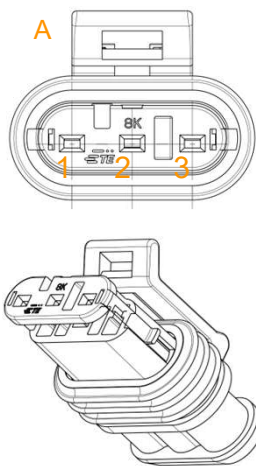

Dia. 23.1
Cable Connection at Divider



Dia. 23.2
Cable kit-
divider monitoring
With BD plug

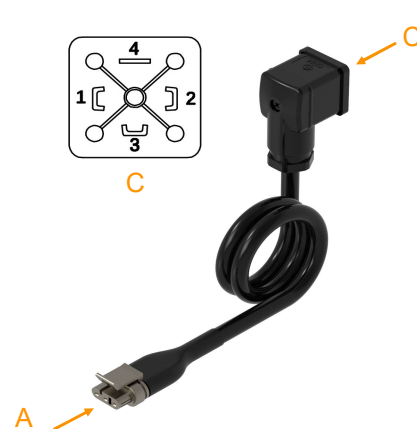

Dia. 23.3
Cable kit-
divider monitoring
with HSC plug

Divider Accessories

Divider tie rods

The JPQ1 divider can be adjusted to the delivery quantity and the number of lubrication points due to its disc construction. Elements can be added or removed.

The tie rods must be tightened with a torque of 12 +/- 1 Nm.

Divider type	Tie rod type (L=50 to 125)	Part no.
JPQ1 - 3/6	M6 x 50	3040103160
JPQ1 - 4/8	M6 x 65	3040103170
JPQ1 - 5/10	M6 x 80	3040103180
JPQ1 - 6/12	M6 x 95	3040103190
JPQ1 - 7/14	M6 x 110	3040102940
JPQ1 - 8/16	M6 x 125	3040102950
JPQ1 - 9/18	M6 x 140	3040105480
JPQ1 - 10/20	M6 x 155	3014001525

Part no.: Pos. 2 for spring washer D6: 3040100100

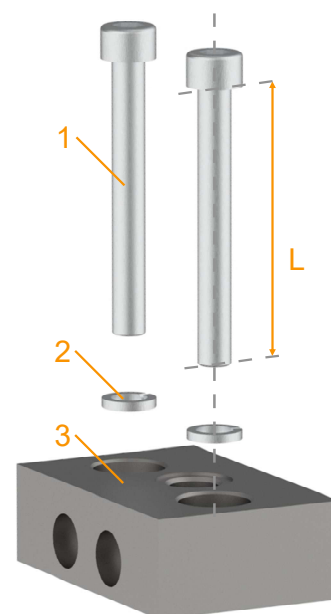

- 1 Tie rod
- 2 Spring washer
- 3 Start element

Dia. 24.1

Tie rods and spring washers for divider elements connection

Standard package for divider elements *

Description	Package size	Pieces per box	Part no.
SE	340mm x 200 mm x 145mm	60	2020520330
ME-08-N		70	2020520290
ME-16-N		70	2020520300
ME-24-N		70	2020520310
ME-32-N		70	2020520320
EE-08-N		40	2020520260
EE-16-N		40	2020520270
EE-24-N		40	2020520280
EE-32-N		40	2020520520

* Only normal SE, ME and EE divider elements (without in/outlets, sensors or indication pins) can be ordered with a standard package.

Divider Accessories

Manual emergency lubrication via banjo grease nipple

As an option, a banjo with grease nipple is provided to using a manual or hydraulic pump to refill the grease direct from the start element of the divider when the automatic lubrication pump does not work.

Attention: Please check the hoses between the banjo and the pump outlet before starting refilling grease from the banjo!

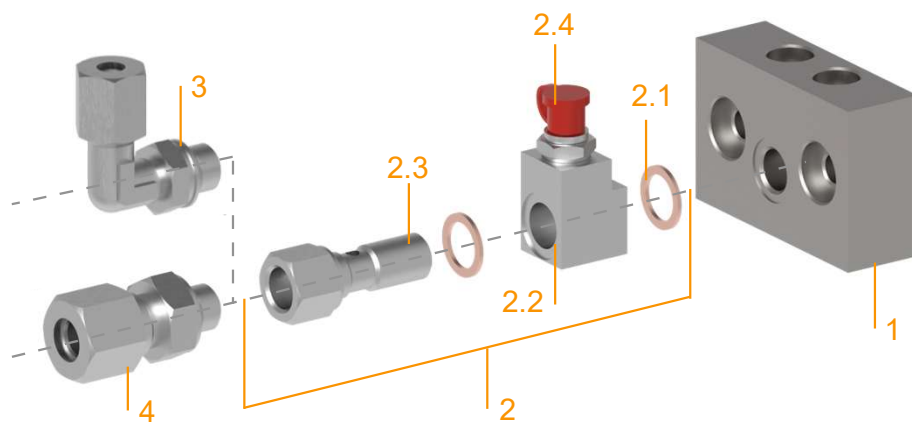

- 1 Start element
- 2 Banjo grease nipple
 - 2.1 Sealing ring
 - 2.2 Banjo block body
 - 2.3 Extension
 - 2.4 Grease nipple
- 3 Elbow screw coupling
- 4 Straight screw coupling

Dia. 25.1

Description		Part no.
Extension with grease nipple (swivel)-M10x1-M10x1-38,5-ST-ZnNi (incl. parts 2.1, 2.2, 2.3, 2.4)		3050105240
Spare parts 2.1	Qty. per set	
Sealing ring-DR-DIN7603 A-10x14x1-Cu	2	3010401930
Spare parts 2.4		
Grease nipple-M10x1-straight-SS	1	5010000080

Order Key JPQ1

JPQ1 - 5 / 6 - 100 - 16*-8L0-8*-24*-24 . 000

No. of valid elements ME (Middleelements) + EE (Endelements)
3 = 2ME + 1EE
4 = 3ME + 1EE
5 = 4ME + 1EE
6 = 5ME + 1EE
7 = 6ME + 1EE
8 = 7ME + 1EE
9 = 8ME + 1EE
10 = 9ME + 1EE

No. of valid outlets
X

Fittings in divider inlets and outlets							
Outlet \ Inlet	None	Straight D6mm	Straight D8mm	Elbow D6mm	Elbow D8mm	Swivel D6mm	Swivel D8mm
	None	100	106	112	118	124	130
RDGE	101	107	113	119	125	131	137
RGE	102	108	114	120	126	132	138
GE	103	109	115	121	127	133	139
ÜS	104	110	116	122	128	134	140
GES	105	111	117	123	129	135	141

Type of elements	Middle elements ME				End elements EE			
Standard (without Sensor)	8	16	24	32	8	16	24	32
with Sensor PNP (Position: mounted right of the divider)	/	16P	24P	32P	/	16P	24P	32P
with Sensor NPN (Position: mounted right of the divider)	/	16N	24N	32N	/	16N	24N	32N
Without sealing ball and sealing screw	XX*				XX*			
Combined element and outlet on left	XX*L				XX*L			
Combined element and outlet on right	XX*R				XX*R			
Bridged with next element with outlets on left	XX*L1 or XXL1				/			
Bridged with next element without outlets on left	XX*L0 or XXL0				/			
Bridged with next element with outlets on right	XX*R1 or LLR1				/			
Bridged with next element without outlets on right	XX*R0 or XXR0				/			

Special models	
Standard version	000
Customized version	XXX

Sample order :

JPQ1-5/6-100-16*R-8L0-8*-24*L-24P.000

- 5/6 ≙ Progressive divider-JPQ1 with 5 Divider elements (4ME + 1EE with 10 Outlets of which 6 Outlets are used)
- 100 ≙ No Inlet Screw Couplings, no Outlet Screw Couplings
- 16*R ≙ Middle element ME16 without sealing ball and sealing screw with screw plug
- 8L0 ≙ Middle element ME08 bridged without outlet on the left
- 8* ≙ Middle element ME08 without sealing ball and sealing screw
- 24*L ≙ Middle element ME24 without sealing ball and sealing screw
- 24P ≙ End element ME24 with divider monitoring sensor PNP
- 000 ≙ No customization

The following flow rates are delivered by the progressive divider:

- SE → Divider inlet and mounting holes
- ME-16 → 320 mm³ on the right outlet
- ME-8 → 80 mm³ on the right outlet
- ME-8 → 80 + 80 + 80 mm³ = 240 mm³ on the right outlet
- ME-24 → 480 mm³ on the left outlet
- EE-24 → je 240 mm³ on the right and left outlet and divider monitoring sensor PNP on the right

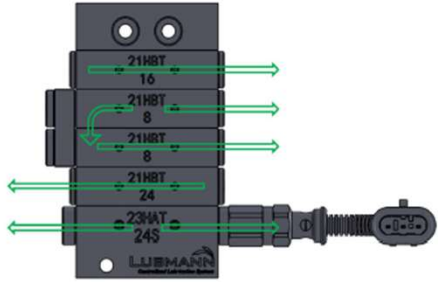

Special version FKM (Viton seals)

The JPQ1 Divider is also available with an FKM seal (Viton) between the start, middle and end elements.

The functional description corresponds to the standard version JPQ1 in this instruction.

Technical data:

Operating pressure - Inlet:	max. 300 bar
Temperature range:	-35°C to +70°C
Lubricant:	Oil-fluid grease-Grease up to NLGI-KI.-2
In- / Outlet Thread:	M10x1
Number of elements:	
Min.:	JPQ1_FKM 3/6 (3 output elements)
Max.:	JPQ1_FKM 9/18 (9 output elements)

If required, please use the order numbers on the following pages.

Start Element (SE)

Start element is the element without outlets (*Dia. 27.1*).
Every divider must have a start element.

Description	Part No.	
JPQ1_FKM-Start element SE, incl. O-Ring Set & Pin		15010014
Spare Parts	Qty. per Set	
O-Ring-7,5x1,5-SH80-FKM	4	15010015
O-Ring-2,5x1,5-SH80-FKM	1	15010016
Cylinder pin-JPQ1-D3x8-A2	1	3040100050

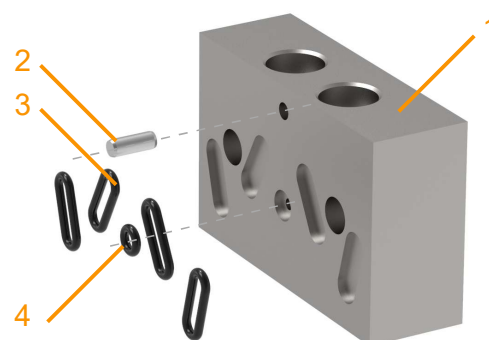

- 1 Start Element Body
- 2 Cylinder pin
- 3 O Ring
- 4 O Ring

Dia. 27.1
Start Element (SE)

Special version FKM (Viton seals) Middle Element (ME)

The middle elements ME-16-S, ME-24-S and ME-32-S in *Dia.* 13.2 have the possibility to be installed with a divider monitoring sensor right or left side of the elements.



The Kit-divider monitoring sensor must be ordered separately!

Technical data and part no. for divider monitoring sensor please check on page 22.

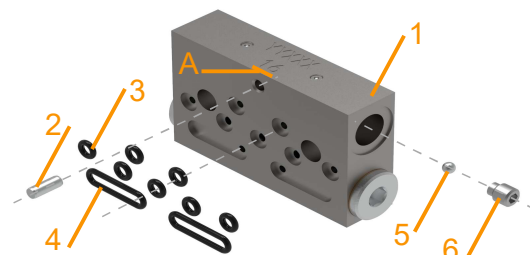

- 1 Middle Element Body
- 2 Cylinder pin
- 3 O Ring
- 4 O Ring
- 5 Sealing steel ball
- 6 Sealing screw

Dia. 28.1
Middle element (ME)

Description	Possibility to be installed with a divider monitoring sensor *	With in- and outlets screw couplings	Part no.
ME-08-N	No	No	15010017
ME-16-N	No	No	15010018
ME-24-N	No	No	15010020
ME-32-N	No	No	15010021
ME-16-S	Yes	No	15010022
ME-24-S	Yes	No	15010023
ME-32-S	Yes	No	15010024

All middle elements in the table above include cylinder pin, o ring sealing set, sealing steel ball and sealing screw.

Spare Parts – Middle elements	Qty. per Set	Part no.
Cylinder pin-JPQ1-D3x8-A2	1	3040100050
O-Ring-2,5x1,5-SH80-FKM	7	15010016
O-Ring-11,5x1,5-SH80-FKM	2	15010025
Sealing screw for divider outlet separation-M4-ST	1	3040102550
Sealing steel ball for divider outlet separation-D3-ST	1	3049000450

The sealing screw and steel ball can only be taken out from the right-side outlet of the elements (*Dia.* 13.1).

Packaging units PU of the individual distributor disks in a box

Description	Box dimensions	Qty. per box	Part no.
SE	340mm x 200 mm x 145mm	60	15010014
ME-08-N		70	15010017
ME-16-N		70	15010018
ME-24-N		70	15010020
ME-32-N		70	15010021

Only divider elements without inlet and outlet fittings and without sensor, can be supplied in a box.

Order Key JPQ1_FKM

JPQ1_FKM - 5 / 6 - 100 - 16*-8L0-8*-24*-24 . 000

No. of valid elements
ME (Middleelements) + EE (Endelements)

3 = 2ME + 1EE (sealing with viton)
4 = 3ME + 1EE (sealing with viton)
5 = 4ME + 1EE (sealing with viton)
6 = 5ME + 1EE (sealing with viton)
7 = 6ME + 1EE (sealing with viton)
8 = 7ME + 1EE (sealing with viton)
9 = 8ME + 1EE (sealing with viton)
10 = 9ME + 1EE (sealing with viton)

No. of valid outlets

X

Fittings in divider inlets and outlets

Outlet \ Inlet	Fittings						
	None	Straight D6mm	Straight D8mm	Elbow D6mm	Elbow D8mm	Swivel D6mm	Swivel D8mm
Keine	100	106	112	118	124	130	136
RDGE	101	107	113	119	125	131	137
RGE	102	108	114	120	126	132	138
GE	103	109	115	121	127	133	139
ÜS	104	110	116	122	128	134	140
GES	105	111	117	123	129	135	141

Type of elements	Middle elements ME				End elements EE			
Standard (without Sensor)	8	16	24	32	8	16	24	32
with Sensor PNP (Position: mounted right of the divider)	/	16P	24P	32P	/	16P	24P	32P
with Sensor NPN (Position: mounted right of the divider)	/	16N	24N	32N	/	16N	24N	32N
Without sealing ball and screw	XX*				XX*			
Combined element and outlet on left	XX*L				XX*L			
Combined element and outlet on right	XX*R				XX*R			
Bridged with next element with outlets on left	XX*L1 or XXL1				/			
Bridged with next element without outlets on left	XX*L0 or XXL0				/			
Bridged with next element with outlets on right	XX*R1 or LLR1				/			
Bridged with next element without outlets on right	XX*R0 or XXR0				/			

Special models

Standard version	000
Customized version	XXX

Sample order :

JPQ1_FKM-5/6-100-16*R-8L0-8*-24*L-24P.000

- 5/6 ≙ Progressive divider-JPQ1 with 5 Divider elements (4ME + 1EE with 10 Outlets of which 6 Outlets are used)
- 100 ≙ No Inlet Screw Couplings, no Outlet Screw Couplings
- 16*R ≙ Middle element ME16 without sealing ball and sealing screw with screw plug
- 8L0 ≙ Middle element ME08 bridged without outlet on the left
- 8* ≙ Middle element ME08 without sealing ball and sealing screw
- 24*L ≙ Middle element ME24 without sealing ball and sealing screw
- 24P ≙ End element ME24 with divider monitoring sensor PNP
- 000 ≙ No customization

The following flow rates are delivered by the progressive divider:

- SE → Divider inlet and mounting holes
- ME-16 → 320 mm³ on the right outlet
- ME-8 → 80 mm³ on the right outlet
- ME-8 → 80 + 80 + 80 mm³ = 240 mm³ on the right outlet
- ME-24 → 480 mm³ on the left outlet
- EE-24 → je 240 mm³ on the right and left outlet and divider monitoring sensor PNP on the right

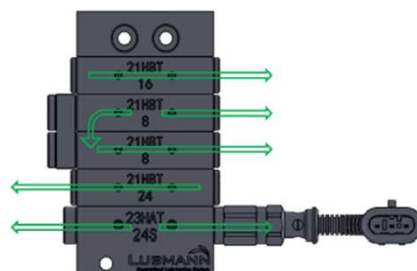

Troubleshooting

Fault	Possible Cause	Solution
Lubrication points get no or insufficient lubricant	Lubrication pump is empty	Refill lubricant
	Clogged or broken lubrication hose	Replace lubrication hose
	Unsuitable lubricant	Replace lubricant
	Unsuitable or defective outlet fittings (non-return valve) at the divider outlets	Check outlet fittings
	Blockage before the inlet of the main divider	Disconnect the hose from the pump to the main divider and check whether lubricant is leaking from the hose. If no lubricant is dispensed, the defect is from the hose to the main divider or the grease lubrication pump.
	Blockage on main divider	Disconnect the hose from the main divider to the secondary divider individually and check whether lubricant is leaking at the outlet of the main divider. If no lubricant is dispensed, the cause is from the main divider or the hose. Clean / replace the main divider if necessary.
	Blockage on secondary divider	Disconnect the hose from the secondary divider to the lubrication point individually and check whether lubricant is leaking at the outlet of the secondary divider. If no lubricant is dispensed, the cause is from the secondary divider or the hose. Clean / replace the secondary divider if necessary.
	Blockage of a lubrication point	Disconnect the hose from the secondary divider to the lubrication point individually and check whether lubricant is leaking at the outlet of the secondary divider. If lubricant is dispensed, the cause is from the lubrication point. Clean / replace the grease nipple if necessary.
A lubrication point gets too much or not enough lubricant	Wrong dosing quantity at the divider	Replace the divider elements according to the requirements.
	Incorrect pump setting	Check the pump working and pause time, and adjust if necessary.
	<p>Please also refer to the troubleshooting information in the operating instructions for the grease lubrication pump used.</p> <p>To check, the grease lubrication pump must be in operation and several lubrication cycles must have run so that the main dividers and any secondary dividers are sufficiently supplied with lubricant.</p>	