

Operating- and assembly manual

Grease lubrication pump ALPB

12-24V DC - BYN



Index

Declaration of incorporation	3
CE certification	4-6
Legal disclosure	7
Safety instructions	8-10
Lubricant	10
Technical data	11-33
Overview	11-12
Working Principle	13
Pump element	14-15
Safety valve SV - C / SV - A	16-18
Installation dimensions	19
Low level indication	20
Integrated Controller and Monitoring	21-25
Internal and external wiring connections	26-27
Filling of the pump	28
Explosion Drawing	29-30
General BOM	31-33
Delivery, returns and storage	34-35
Installation	35-36
Trouble shooting	37
Shutdown and disposal	38
Order key	39

Rev	Revision:	Date / Author:	Date / Release:
R01	Cover and order key updated	12.03.25/HB	12.03.25/RJ

Declaration of incorporation

Declaration of incorporation for incomplete machinery (acc. To EC-directive 2006/42/EG)

The manufacturer: Lubmann GmbH, Kleiner Johannes 21, 91257, Pegnitz, Germany

declares hereby, that the following partly completed machinery:

Designation: Centralized lubrication pump
Type: ALPB
Part No.: 20xxxxxxxx / 99xxxxx / 15xxxxxx

is complying with all essential requirements of the above-mentioned machinery directives (2006/42/EG):

Annex I, article 1.1.2, 1.1.3, 1.1.5, 1.3.2, 1.3.4, and 1.5.1.

The following coordinated standards have been used:

DIN EN 809
DIN EN ISO 12000

The following other specifications and standards have been used:

VDE 0530

The protection targets of the directive for have been electric equipment 2006/95/EG observed according to the annex I, no. 1.5.1 of the machine directive.

The incomplete machine may only be put into service as soon as there has been stated that the machine, into which the incomplete machine shall be installed, responds to the determinations of the machine directive (2006/42/EG).

The special documentation that responds to the machine, has been prepared according to annex VII-part B.

The manufacturer (documentation department, phone +49 9241 80 89 87 00, email: info@lubmann-gmbh.de) obliges itself to pass on electronically the special documentation for partly completed machinery to individual national authorities upon request.

Pegnitz, 01.10.2022



ppa. Markus Kürzdörfer
General Manager

Lubmann GmbH

CE certification Page 1

TÜV Rheinland (China) Ltd.
Member of TÜV Rheinland Group



Lubmann GmbH
Markus Kürzdörfer

Date : 11.06.2021
Our ref. : WYH 01
Your ref.: M.K.

Dr.-Alfred-Herrhausen-Allee 16
47228 Duisburg
Germany

Ref : AM Certificate of Conformity (Module A)

Type of Equipment : Centralized Lubrication System
Model Designation : See Certificate
Certificate No. : AM 50507162 0001
Report No. : 17705122 003

Dear Markus Kürzdörfer,

We herewith confirm that a sample of the above mentioned technical equipment has been tested and was found to be in accordance with the relevant requirements.

Enclosed please find your Certificate of Conformity.

We appreciate your kind support and would like to offer our assistance and continuous services in the future.

With kind regards,

Certification Body

Huajian Dong

Enclosure

证书的详细资料请登陆www.certipedia.com查阅,或拨打我司客服热线800 999 3668 / 400 883 1300咨询



TÜV Rheinland (China) Ltd.
莱茵检测认证服务(中国)有限公司

Unit 707, AVIC Bldg., No. 10B,
Central Road, East 3rd Ring
Road, Chaoyang District,
Beijing, 100022, P.R.China

北京市朝阳区东三环中路乙10号
艾维克大厦707室
邮编: 100022

Tel: (8610)6566 6660
Fax: (8610)6566 6667
e-mail: info@bj.chn.tuv.com
Internet: <http://www.chn.tuv.com>

CE certification Page 2

C E R T I F I C A T E		 TÜVRheinland
of Conformity EC Council Directive 2006/42/EC Machinery		
Registration No.:	AM 50507162 0001	
Report No.:	17705122 003	
Holder:	Lubmann GmbH Dr.-Alfred-Herrhausen-Allee 16 47228 Duisburg Germany	
Product:	<u>Grease Pump</u> (Centralized Lubrication System)	
Identification:	Type Designation : ALP8xy (x=1, 2, 3. y=2) ALP10xy (x=1, 2, 3. y=2, 4, 6, 8) (LUBMANN) Serial No. : Engineering sample	
	Remark: Refer to test report 17705122 003 for details. See more module type designations in attachment 1.1	
<p>This certificate of conformity is based on an evaluation of a sample of the above mentioned product. This is to certify that the tested sample is in conformity with all provision of Annex I of Council Directive 2006/42/EC, referred to as the Machinery Directive. This certificate does not imply assessment of the production of the product and does not permit the use of a TÜV Rheinland mark of conformity. The holder of the certificate is authorized to use this certificate in connection with the EC declaration of conformity according to Annex II of the Directive.</p>		
Date	11.06.2021	 Certification Body TÜV Rheinland LGA Products GmbH TÜV Rheinland Huajian Dong Zertifizierungsstelle
TÜV Rheinland LGA Products GmbH - Tillystraße 2 - 90431 Nürnberg		
CE The CE marking may be used if all relevant and effective EC Directives are complied with. CE		

CE certification Page 3



1.1

TÜV Rheinland
LGA Products GmbH
Tillystraße 2, 90431 Nürnberg

Attachment to
Registration No.: AM 50507162 0001
Report No.: 17705122 003

Manufacturer: Lubmann GmbH
Dr.-Alfred-Herrhausen-Allee 16
47228 Duisburg
Germany

Scope: Type Designation:
ALPA8xy (x=1, y=1, 2)
ALPA10xy (x=1, 2. y=2, 4, 6)
ALPA12xy (x=1, 2. y=4, 8, 10, 15, 20, 30)
ALPB10xy (x=1, 2. y=2, 4, 6)
ALPB12xy (x=1, 2. y=4, 8, 10, 15, 20, 30)
ALPB13xy (x=1, 2. y=15, 20, 30)
(LUBMANN)
Serial No.: Engineering sample

Remark: Refer to test report 17705122 003 for details.

Date: 2021-06-11

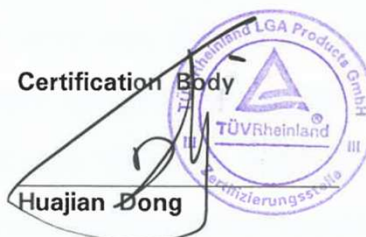

Legal disclosure

Manufacturer

Lubmann GmbH
Add: Kleiner Johannes 21, 91257, Pegnitz, Germany
E-Mail: info@lubmann-gmbh.de
Website: www.lubmann-gmbh.de

Training courses

In order to provide a maximum of safety and economic viability, Lubmann GmbH carries out detailed training courses. It is recommended that the training courses are attended. For more information, please contact Lubmann GmbH.

Copyright

© Copyright Lubmann GmbH All rights reserved.

Warranty and extent of warranty



Inappropriate intervention will rule out your warranty claim!

Warranty regarding operational safety, reliability and performance of the lubricating pump is only accepted by the manufacturer under the following conditions:

- Assembly, connection, setting, maintenance and repair are carried out by authorized and specialized staff.
- The limits stipulated in the technical data must never be exceeded.
- Only original components or components approved by the manufacturer may be used for repair and maintenance work.

All guarantees and warranties expire for damages to central lubrication systems that are caused by operation with improper lubricants (e.g., piston wear, piston jamming, plugins, embrittled sealings).

Lubmann does not assume liability on damages caused by lubricants, even if these lubricants have been tested and released by laboratory tests, as damages caused by lubricants (e.g., by expired or improper stored lubricants, batch variations etc.) can not be retraced to their root cause in retrospect.

Service address

Kleiner Johannes 21, 91257, Pegnitz, Germany
Tel.: +49 9241 80 89 87 00

Explanation of symbols



Safety instructions which, if not complied with, may endanger persons, are marked specifically with the general hazard symbol:



This heading is used if inaccurate compliance or non-compliance with the Operating Instructions or specified work procedures etc. may result in damage



Points out Special Information

Disclaimer

The manufacturer shall not be held responsible for damages caused by:

- Non appropriate use faulty assembly, operation, setting, maintenance, repair or accidents
- Use of inappropriate lubricants
- Improper or late response to malfunctions
- Unauthorized modifications of the product
- Intent or negligence
- Use of non-original Lubmann spare parts
- Faulty planning or layout of the centralized lubrication system

Liability for loss or damage resulting from the use of our products is limited to the maximum purchase price. Liability for consequential damages of whatever kind is excluded

Safety instructions

General information

Any safety-related faults must be eliminated without delay.

Below, please find fundamental instructions to be complied with, regarding assembly, operation and maintenance. The mechanical and the competent specialists / staff of the operating company must read the Operating Instructions on all accounts prior to starting assembly and commissioning. Moreover, the Operating Instructions must permanently be available on site.

Not only the safety instructions included under this item, but also the specific safety instructions appearing in other parts of this manual must be complied with.,

General risk reference

All system components have been designed in view of operational safety and accident prevention according to the applicable provisions for the design of technical equipment.

Nevertheless, utilization thereof may result in risks for the user or third parties and/or technical equipment. Thus, the system may only be used in proper technical working within its intended fields of application and in compliance with the safety provisions and the Operating Instructions.

Personal:

The staff in charge of operation, maintenance, inspection and assembly must be qualified accordingly for this work. The operating company must stipulate competences, responsibilities and the supervision of staff precisely. If the staff does not dispose of the appropriate knowledge, they must be trained and instructed. The operating company must ensure that the staff have understood the contents of the Operating Instructions

Danger due to non-observance of the safety information

Non-compliance with the safety information may put persons at risk and endanger the environment and/or the machine. Non-compliance with the safety instructions may rule out any claims for damages.



Non-compliance may lead, e. g. to the following dangers:

- Failure of important system functions,
- Failure of the specified maintenance and servicing methods,
- Endangering people due to electrical, mechanical and chemical effects,
- Endangering the environment due to leakages of dangerous materials.

Use in conformity with the intended purpose:

The pumps of the series ALPB serve only for the supply of central lubrication pumps at vehicles, systems and machines. Any use beyond this scope is regarded as being not in conformity with the intended purpose.

Assembly and maintenance



Observe for all assembly works at vehicles, systems and machines the valid local accident prevention regulations and safety instructions as well as the specifications for operation and maintenance.

All maintenance, inspection and assembly work may only be carried out by trained specialists. All work must only be carried out when the plant is at a standstill and while wearing appropriate protective clothing.

All the safety and protective equipment must be replaced immediately after completing work. Media that endangers the environment must be disposed in accordance with pertinent official specifications. Secure the system during maintenance and repair works, against intentional or unintentional reoperation.

Dispose of process materials in accordance with the safety data sheets of the lubricant manufacturer.

Safety information for operators/operating staff



- If hot or cold machine parts led to hazards, the customer must secure them from being touched. The guards on moving or rotating parts must not be removed.
- Drain leakages of dangerous materials in a way, that people or the environment are not endangered.
- Comply with legal regulations.
- Exclude any hazards by electric energy.

Unauthorized modification and spare part production



Modifications and alterations of the system require the manufacturer's prior approval. Original spare parts and accessories authorized by the manufacturer serve for higher safety. The use of other parts may rule out liability for the consequences of such use. For components, which are retrofitted by the operator, Lubmann does not assume liability nor claims for compensation.

Danger caused by the electrics



The units may be connected to the power supply exclusively by appropriately trained qualified personal in conformity with the local connection conditions and regulation (e. g. DIN, VDE)!

Improperly connected equipment may lead to serious personal injury and damage to property!

Danger caused by system pressure



The units might be under pressure. Make them pressure less before you start with repairs, changes or extensions.

Use of hydraulic hose lines:



Installing hydraulic hose lines at the pump, the operator must observe respectively ensure the following items:

- Checks for proper assembly and function must be carried out according to the regional valid guidelines.
- Checks for a safe provisioning and use must be carried out according to the regional valid guidelines.
- The check deadline must not be exceeded.
- Exchange defect hydraulic hose lines immediately and professional.
- Hydraulic hose lines subject to a wear process and must be exchanged regularly and according to the manufacturer's details.

Cleaning

The pump has an IP65 protection rating! It is not allowed to clean the Lubmann pumps with a high-pressure washer. The high-pressure spray can allow water to penetrate the seals into the pump. We do not provide a warranty when high-pressure washers are used!



Lubricant

The system has been designed for commercially available multi-purpose greases of NLGI class 2 for operation in summer and winter.

- Use greases with high-pressure additives (EP greases).
- Only use greases of the same saponification type.
- Lubricants containing solid contents must not be used (lubricants like graphite or MoS2 on request).
- Observe the vehicle manufacturer's specifications, when you select the lubricant.



Hazards to environment cause by lubricants

The lubricants which are recommended by the manufacturer of your vehicle, system or machine correspond in their composition to the common safety regulations. Mineral oils and greases are generally hazardous to ground water and their storage, processing and transport requires special precautions.

Inadmissible methods of operation



Operational security of the plant is only guaranteed if it is operated in accordance with the operating instructions. The limit values stated in the technical data must not be exceeded under any circumstances.

Transport and storage of the pump

The pumps of the series ALPB are packed commercially, according to the regulations of the recipient country and to the wish of the customer. There are no limitations with respect to land, air or sea transport. Store in a dry place at a temperature of -5° C to +35°C.

Technical data

Overview

Lubmann progressive centralized lubrication pump type - ALPB has been widely used in industries like wind power, mining, metallurgy, machine tools, textiles, food, ports, commercial vehicles, construction machinery, and heavy mechanical equipment, etc.

Our Lubmann automatic lubrication system lubricates all lube points as required through progressive lubrication system. It can reduce the friction resistance, reduce contact wear and decrease the friction surface temperature. Meanwhile, it plays a supporting role of anti-rust, shock absorption and sealing.

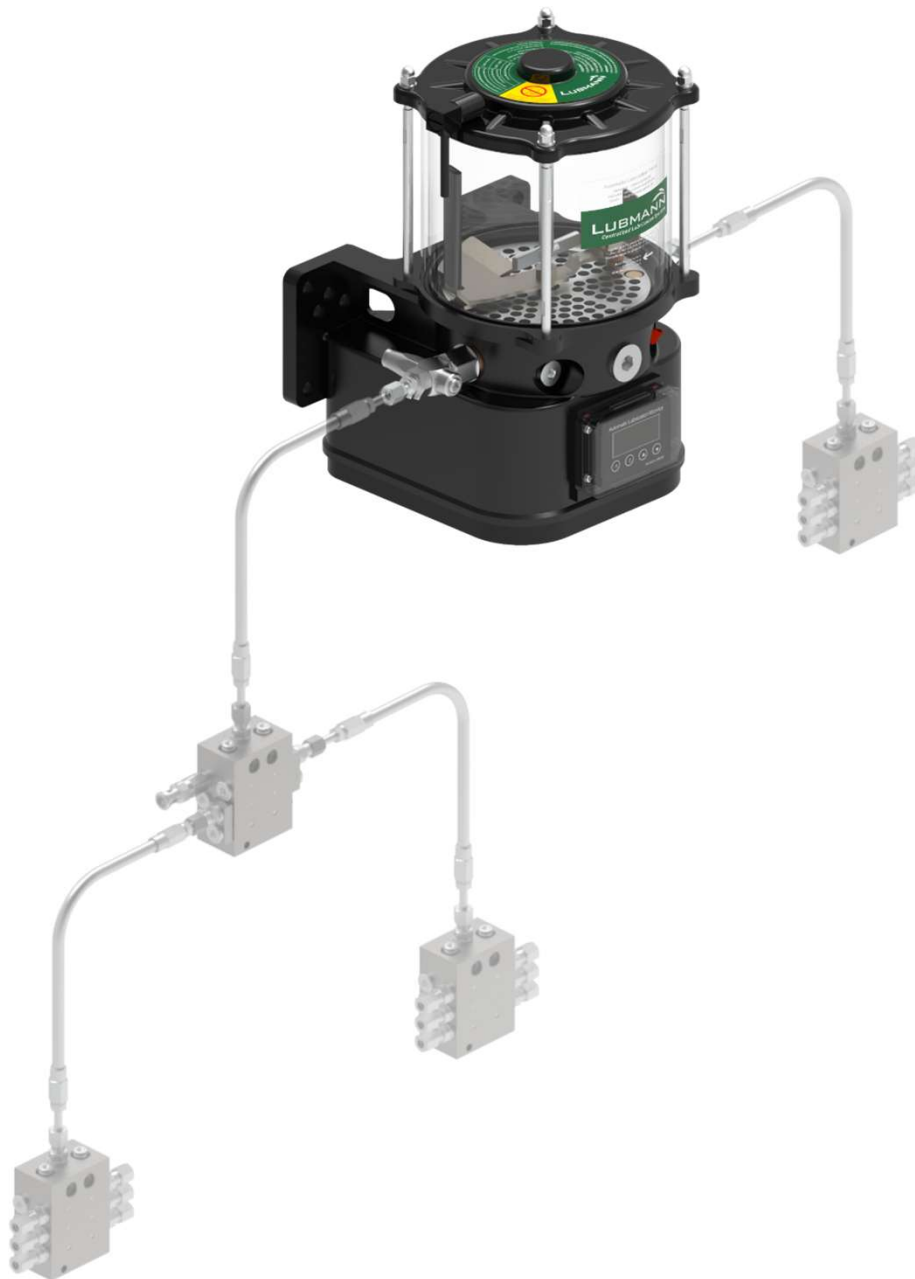

*Dia. 11.1 System Layout for
ALPB Progressive Lubrication Pump + JPQ1 Progressive Dividers*

Overview

The Lubmann progressive central lubrication pump type - ALPB is electrically operated and has up to a max. 4 independently operating lubricant outlets, which can be engaged by bypasses. A separate pump element PE is required for each outlet. Three different delivery rates are available. This allows the grease quantity to be metered precisely for the requirements of the individual progressive distributor layouts.

These pumps enable the delivery of lubricants up to NLGI-Class 2 at a working pressure of maximum 350 bar (adjusting of Safety Valve SV).

The ALPB series pumps differ in reservoir size and control type. It can be controlled by the standard integrated controller with current version AK09* with LED display AK06, or externally by PLC, board computer or external controller from Lubmann.

** The standard integrated controller's version might be upgraded by Lubmann, please check with us for the latest version if necessary.*



Dia. 12.1 Pump with 2/4/6 liter Reservoir - Outside Diameter of Reservoir : 170 mm

Technical data:

Motor:		
Operating Voltage:	12V DC ±10%	24V DC ±10%
Revolutions[rpm]:	20 ± 2	23 ± 2
Relative duty cycle:	30% ED S3 30 minutes	
Current consumption at +20°C:		
Idling:	1A	0.6A
Full load:	5A	3A
Fuse:	10A	6A

Attention: The pump must be protected by a backup fuse in front of the pump to avoid overvoltage damage!



Pump:		
Max. number of pump elements:	4	
Max. Operating pressure:	350 bar	
Preset pressure of safety valve:	300 bar	
Permissible operating temperature:	-35°C to +70°C	
Sound pressure level	<70 dB	
Reservoir size:	2/4/6/8/15/20 L	
Mounting position:	Vertical	
Protection type:	IP65 as per ISO	
Lubricant:	Greases up to NLGI- CI.2 No grease with solids, no oil	



Dia. 12.2 Pump with 8/15/20 liter - Outside Diameter. of Reservoir : 230 mm

Working Principle

A gear DC motor ⑨ continually operates eccentric pressure disc ⑤. This eccentricity effects the suction and pressure strokes of the delivery piston ⑥, whereby the integrated non-return valve ⑦ prevents the delivery media from being sucked back out of the main line.

The stirrer ② pushes the lubricant out of the grease reservoir ① through a screen ④, which reduces any air bubbles, to the suction area in the pump body ③. The stirrer ② enables a visual check of the lubricant volume still present in the transparent supply container ①.

The safety valve is pre-set to 300 bar.

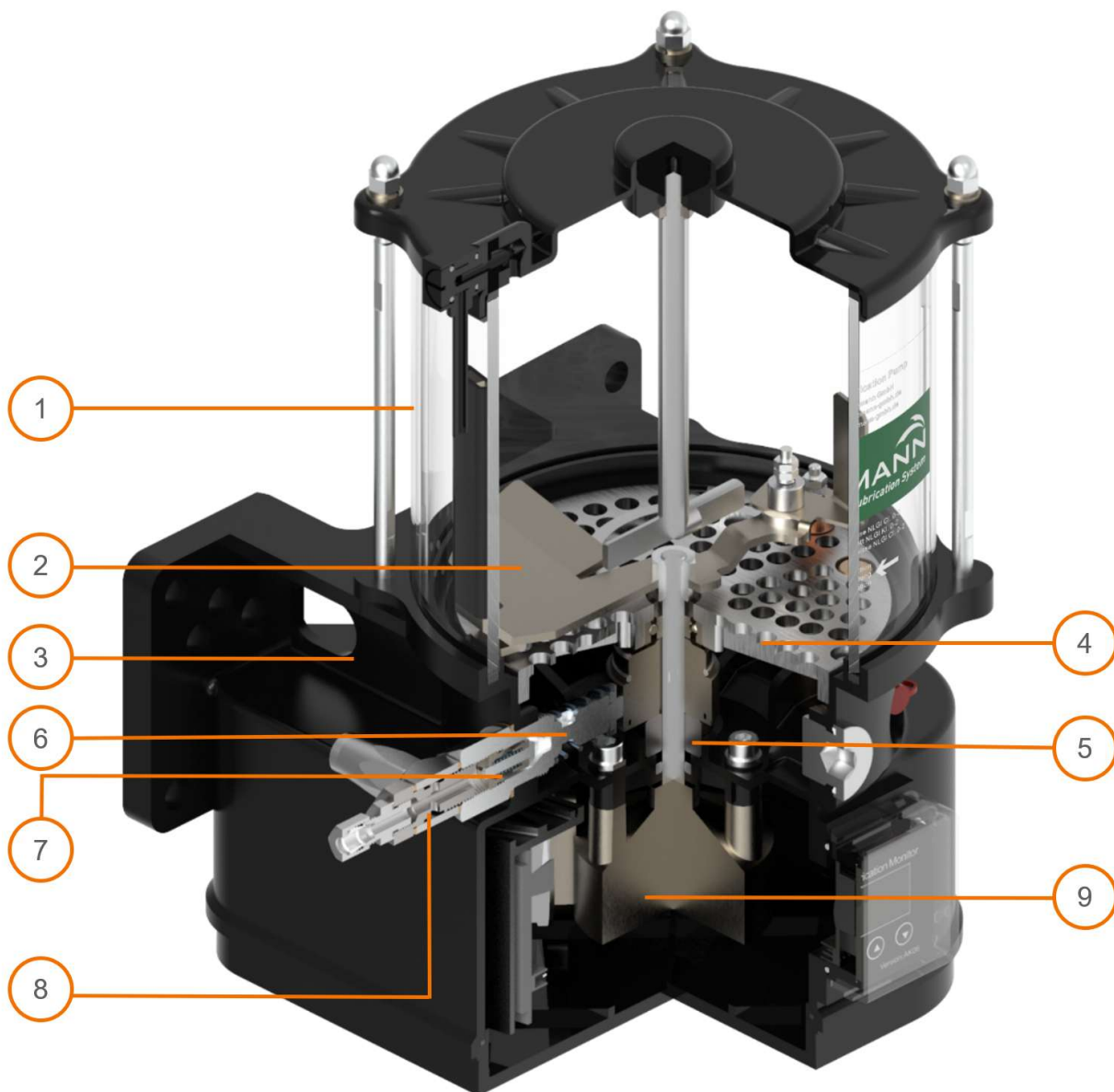

Dia. 13.1 Pump working principle

1. PC Grease reservoir 2. Stirrer 3. Aluminium Pump body 4. Screen 5. Eccentric pressure disc 6. Delivery piston 7. Non-return valve 8. Safety valve 9. Motor

Pump Element

ALPB series pumps can be installed -

max. 4 pump elements with type C safety valve (SV-C without bypass) on the pump outlet position 1/2/3

or

max. 3 pump elements with type A safety valve (SV-A with bypass) on the pump outlet position 1/3*.

* More possibilities for customized Pump Elements setting please contact us.

Pump elements can deliver the grease separately with the flow rate range between 1.5 - 4.5 cm³/min or bridge with each other to achieve a higher flow rate till 13.5 cm³/min with SV-A safety valve

or

till 18 cm³/min with SV-C safety valve*.

* For more information of pump elements bridge please contact us.

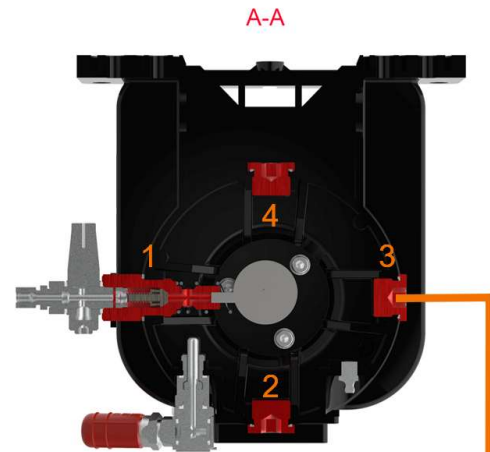

Dia. 14.1 Pump outlets position



Pump outlet blind plug

Order No. 3050105140
(Seal ring incl.)

Technical Data Pump Element (without safety valve):

	Fixed delivery quantity (cm ³ /min)	Order No.	Connecting thread
PE 1.5	1.5	2070011689*	M22x1.5
PE 2.5	2.5	2070011690*	M22x1.5
PE 4.5	4.5	2070011691*	M22x1.5

* Order No. for PE1.5/2.5/4.5 includes Copper Ring already, but without safety valve.

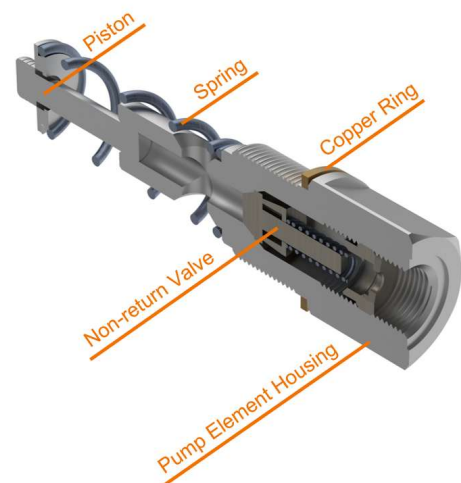

Dia. 14.2 Pump Element structure

Pump Element

Function of Pump Element

On the vertical shaft of the geared DC motor an eccentric pressure disc EPD with eccentric hole in the centre is mounted. When the pump starts running the EPD will make a back-and-forth movement (X1, X2, X3). The pump element is mounted in the pump body the piston of the pump element will run against the EPD.

When the EPD is moving away from the piston (Dia. 15.1-1) the spring on the pump element will push the piston against the EPD. In this suction stroke grease is sucked into the pump element through the 2 suction holes.

See the 2 arrows in (Dia. 15.1-1). The vertical shaft will continue rotating and the EPD will push the piston into the other direction (Dia. 15.1-2). In this pump stroke the piston will close the 2 suction holes and pushes the suctioned grease to the non-return valve.

The pressure created by the piston and grease will open the non-return valve (Dia. 15.1-3) and the grease flows to the outlet of the pump element further into the lubrication system.

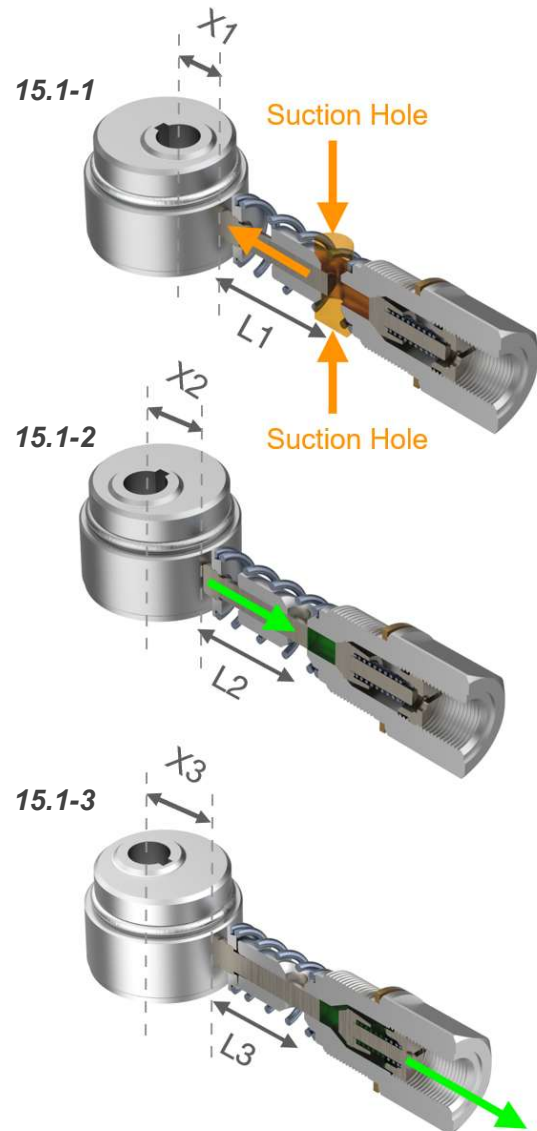

Dia. 15.1 Pump Element Working Principle

Pump Element Installation and Removal

1. Insert the pump element vertically into the pump outlet housing drilling (Dia. 15.2).
2. Tighten the pump element clockwise with a torque wrench, the pre-set value of the torque wrench can not be less than 43 N/m* (Dia. 15.2).

* Value is default setting by original manufacturer.

3. For removal, reserve above sequence.

Only install or remove the pump element when pump power OFF!!!

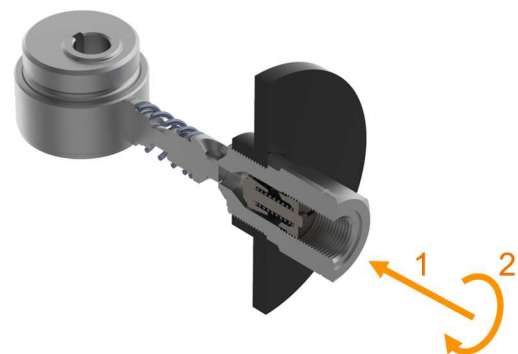

Dia. 15.2 Pump Element installation and removal

Safety Valve Type C: SV-C for PE (Standard Version)

Safety valve Type C: without bypass function
Safety valve Type C: Pre-set to 300 bar

When the system pressure is higher than the pre-set valve (300 bar), the safety valve opens, lubricant flows from the safety valve overflow port out.

Please consider the relevant environmental conditions!

Order No. with Safety Valve Type C		
	Option	Order No.
SV-C*	/	2070011684
Straight Coupling*	LL6	3050100890
	LL8	3050104830
	S6	9901900
Copper Ring	/	3040200510

* For SV-C Order No. 2070011684 already includes the copper rings. For extra Copper Ring Order No. is 3040200510.

* For further information to hose couplings like swivel type or elbow type please check our accessories catalog or contact us.

The default setting by the original manufacturer for the torque value between safety valve and pump element is 36 ± 2 N/m.

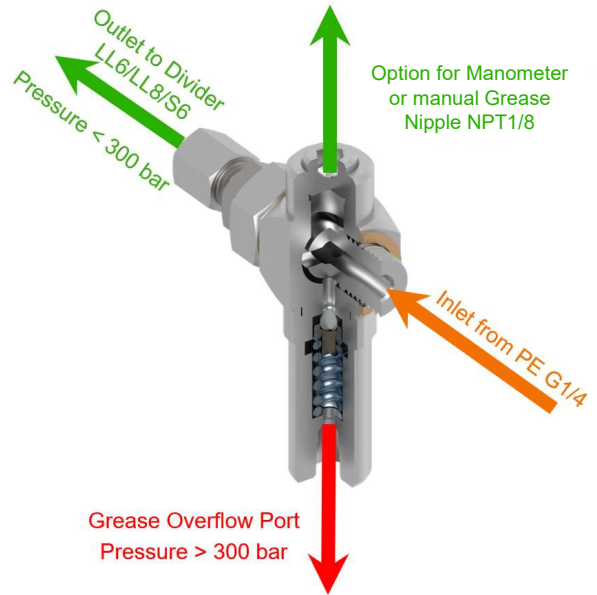

Dia. 16.1 Safety Valve C Working Principle

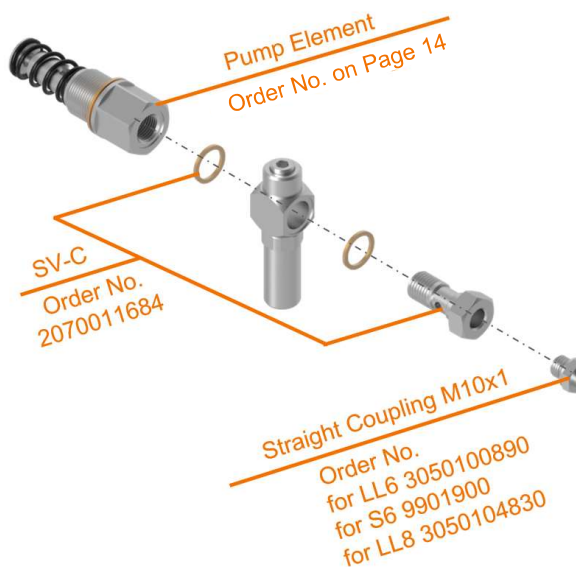

Dia. 16.2 Explosion for SV-C with PE + Straight Coupling

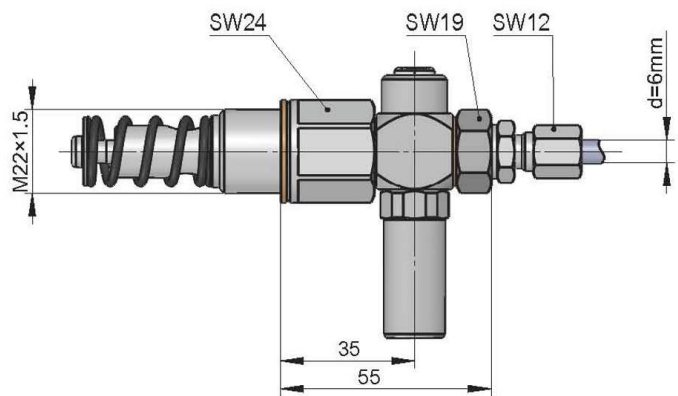

Dia. 16.3 Installation Dimensions for SV-C + PE

Safety Valve Type A: SV-A for PE

Safety valve Type A (SV-A): with bypass function
Safety valve Type A (SV-A): Pre-set to 300 bar

When the system pressure is higher than the pre-set valve (300 bar), the safety valve opens, lubricant flows from the bypass of the safety valve and back to pump reservoir.
Safety valve Type A: single bypass function

Order No. with Safety Valve Type A

	Option	Order No.
SV-A*	/	2011221370
Bypass	Single bypass	2011222820
	Dual bypass	2011026510
Straight Coupling*	LL6	3050100890
	LL8	3050104830
	S6	9901900
Copper Ring	/	3040200510

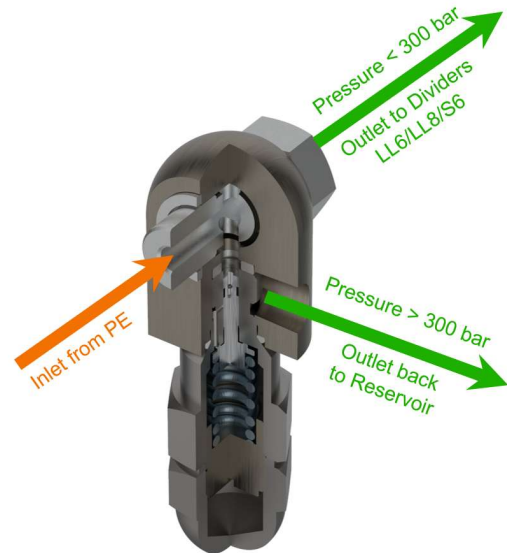

The default setting by the original manufacturer for the torque value between safety valve and pump element is 36 ± 2 N/m.



Dia. 17.1 Safety valve A working principle

* For SV-A Order No. 2011221370 already includes the copper rings. For extra Copper Ring Order No. is 3040200510.

* For further information to hose couplings like swivel type or elbow type please check our accessories catalog or contact us.

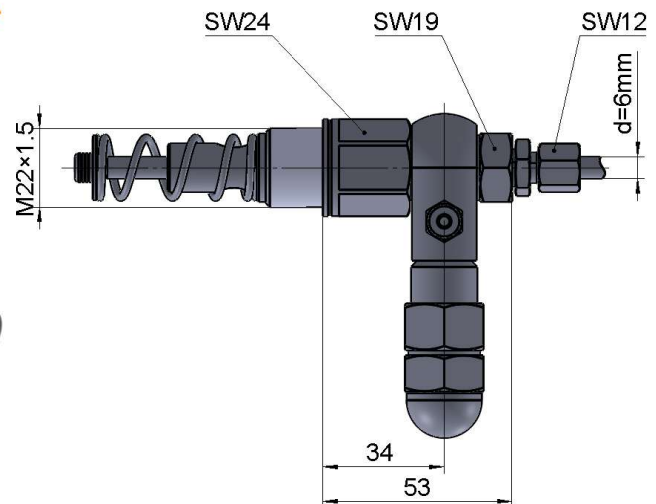
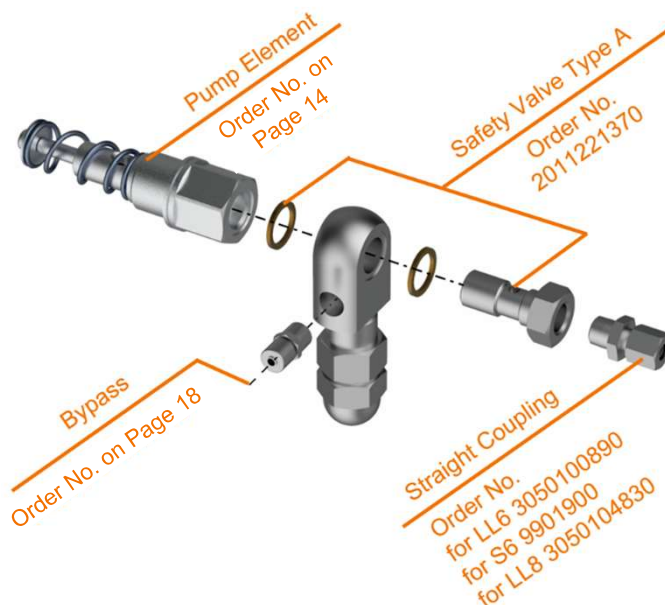

Dia. 17.3 Installation Dimensions for SV-A + PE

Dia. 17.2 Explosion for SV-A with PE + Straight Coupling + Bypass

Grease Bypass Kit for Safety Valve Type A

Single Bypass (Order No. 2011222820)

In *Dia. 18.2* shows the pump with safety valve type A and single bypass, which mainly used for Windmill application.

When the pressure is higher than the pre-set max. value of the safety valve, the grease flows back through the pump element - safety valve - single bypass - pump reservoir.

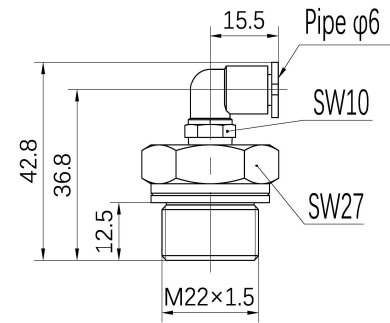

Dia. 18.1 Installation Dimensions of Single Bypass

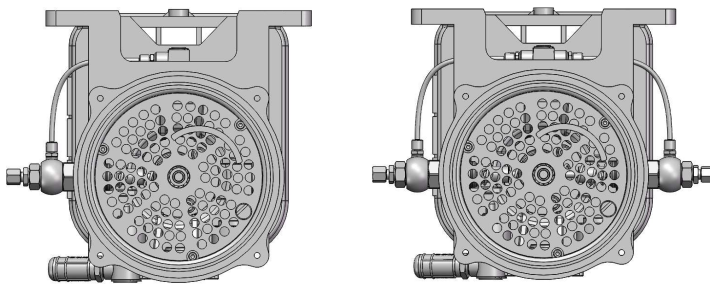

Dia. 18.2 Pump with 1 safety valve type A + Single Bypass

Dia. 18.3 Pump with 2 safety valve type A + Dual Bypass

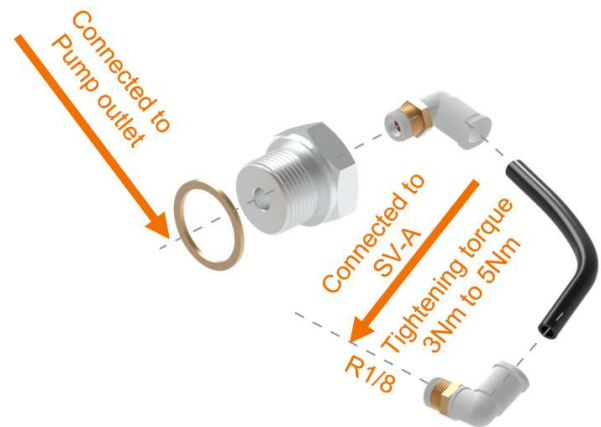

Dia. 18.4 Explosion of Single Bypass

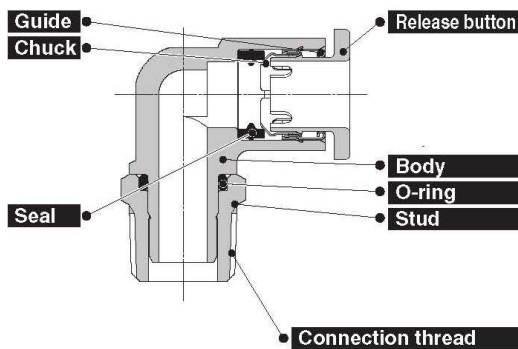

Dia. 15.5 One-touch Fitting for Single Bypass

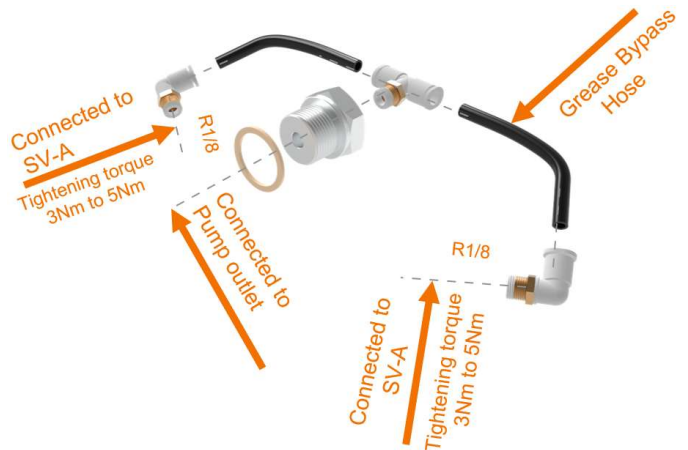

Dia. 18.6 Explosion of Dual Bypass

Dual Bypass (Order No. 2011026510)

In *Dia. 18.3* shows the pump with safety valve type A and dual bypass, which mainly used for Wind mill, heavy metal industry application.

When the pressure is higher than the preset max. value of the safety valve, the grease from the 2 pump outlets flows back through the pump element - safety valve - dual bypass and combined back to pump reservoir.

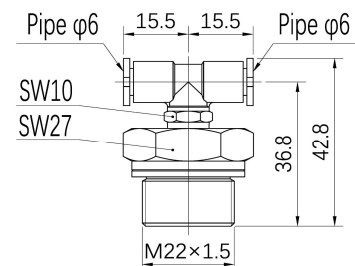

Dia. 18.7 Installation Dimensions of Dual Bypass

Installation Dimensions

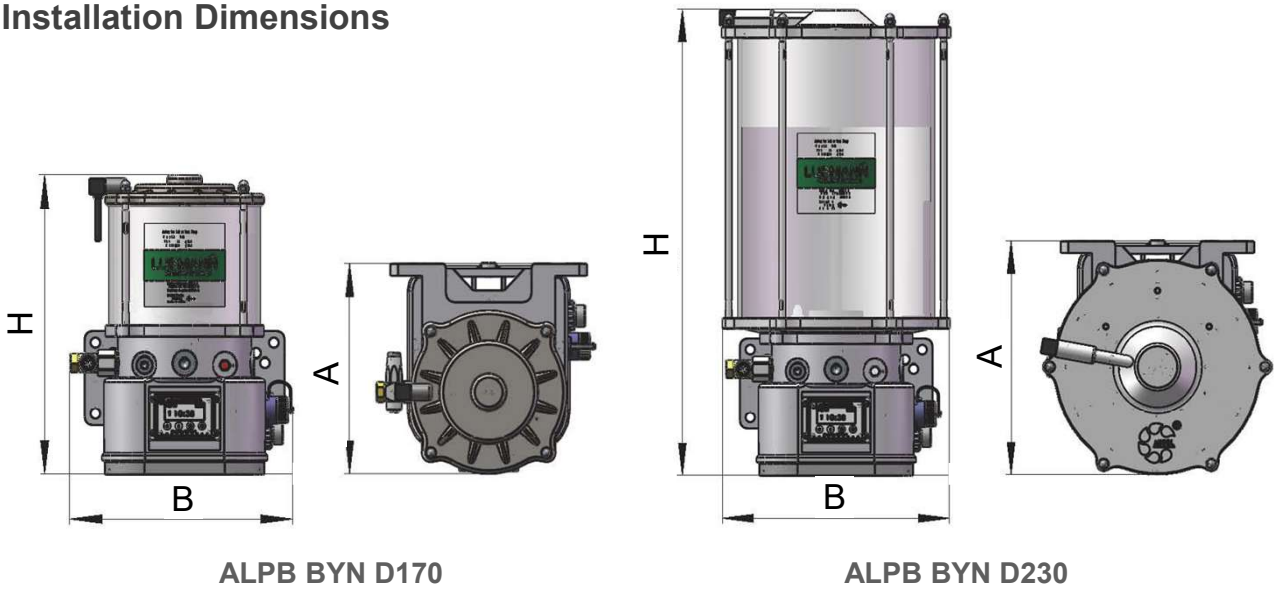

ALPB BYN D170

ALPB BYN D230

Installation Dimensions for ALPB BYN Pump (Stirring Paddle Type)

Capacity	2L D170	4L D170	4L D230	6L D170	6L D230	8L D230	15L D230	20L D230
A (mm)	242	242	259	242	259	259	259	259
B (mm)	235	235	265	235	265	265	265	265
H (mm)	317	462	350	562	416	521	636	769

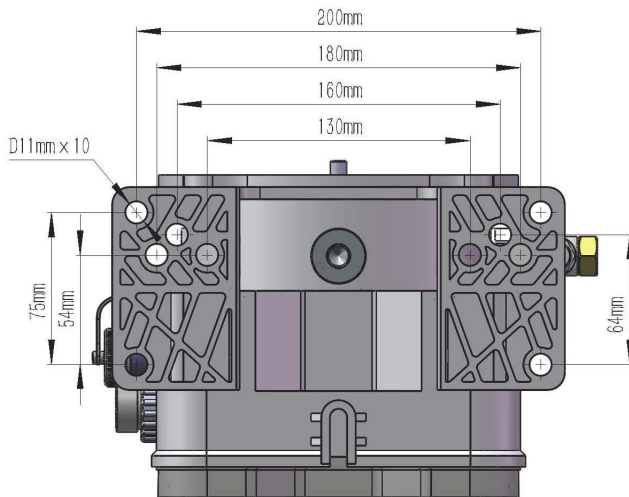

Dia. 19.2 Mounting dimensions for ALPB pump (Stirring paddle type) - on Bottom



Dia. 19.3 Mounting dimensions for ALPB pump (Stirring paddle type) on Top for Pump 15L and 20L

Mounting Dimensions for ALPB Pump (Stirring Paddle Type)

Capacity	15L	20L
H1 (mm)	402	545
C (mm)	160	160

Low-level Indication

Functioning principle of the intermittent grease low-level indication

The intermittent low-level indication operates free of contact. Its main components are the following:

1. firmly positioned magnetic switch *C* inside of the reservoir bottom
2. flexible guide plate *E* connected to the stirring paddle *B* with a magnet *A*
3. A control curved track *D* fixed on the perforated base plate

If the reservoir is filled with a lubrication grease suitable for the intermittent low-level indication and the pump is operating, then the guide plate *E* is deflected by the resistance of the lubrication grease. Therefore, the magnet *A* connected to the guide plate *E* is moved on its inner circuit and cannot trigger a pulse at the magnetic switch *C* with its magnetic field. A control curved track *D* positively guides the magnet together with the pivoted guide plate towards the outside during each revolution. As soon as the guide plate leaves the control curved track, the lubricant's resistance pushes the guide plate together with the magnet to the inside again.

As soon as the lubricant inside the reservoir has fallen to that level that the lubricant's resistance is no more sufficient to further deflect the guide plate *E*, the magnet *A* remains on the outer circuit and can trigger a pulse at the magnetic switch *C* with its magnetic field.

The magnetic switch *C* will send out a pulse signal every time it is triggered. If the magnet *A* slides across the magnetic switch *C* more than 3 times (incl. 3 times) continuously in an operating cycle, the integrated controller of the pump will consider that the amount of grease in the pump is sufficient, otherwise, it is considered that the amount of grease in the pump is insufficient.

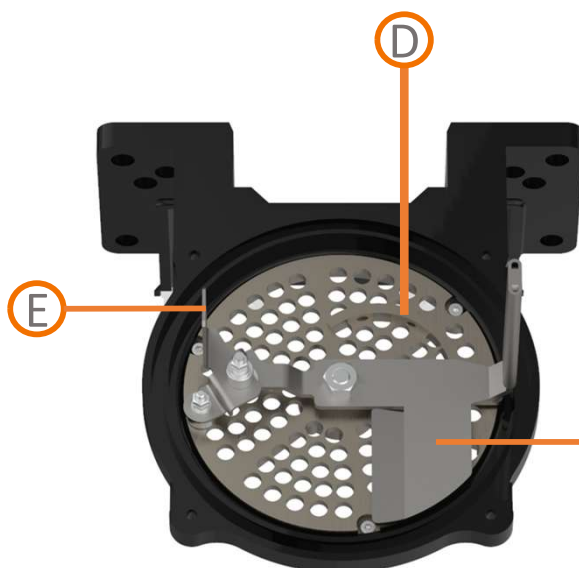

Dia. 20.1 Low level indication perspective representation

A – Magnet, B – Stirring paddle, C – Magnet switch, D – Control curved track, E – Guide plate

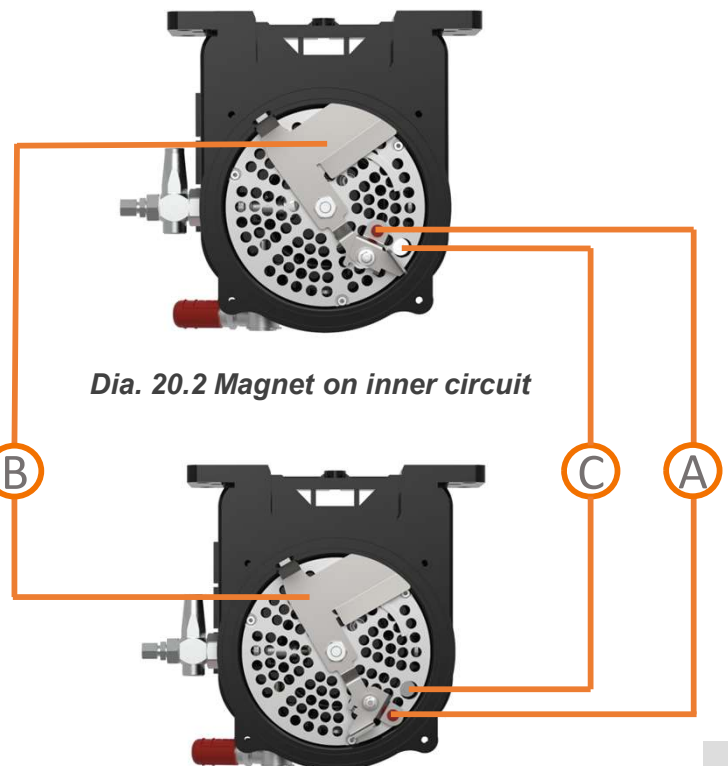

Dia. 20.2 Magnet on inner circuit

Dia. 20.3 Magnet on outer circuit

LED Display AK06 with Integrated Controller AK09

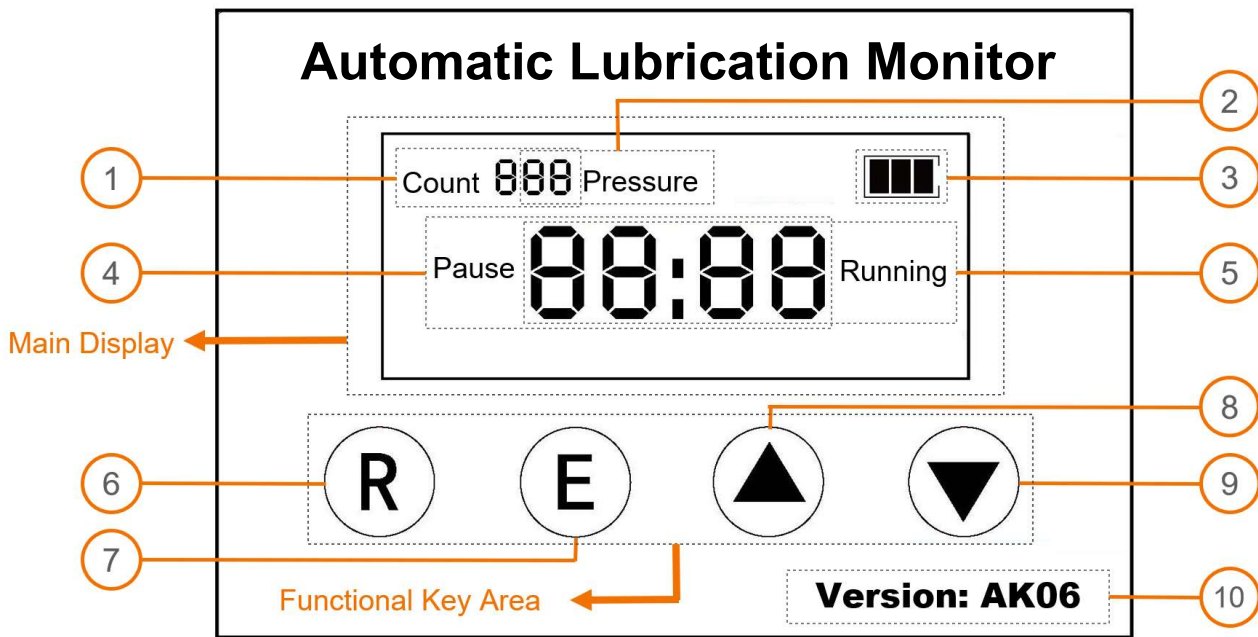

Dia. 21.1 AK06 LED- Display

Our AK09 V5.3 controller / print board is the integrated setting adjustable controller for ALPB BYN Ver. pumps series. The AK06 LED – Monitor / Display Universal works only in combination with the AK09 Setting adjustable controller which can be programmed with different program codes depending on the version (Standard Program Code for ALPB BYN Ver. is d-56).(Dia. 21.1).

Main display / monitor: It shows system status like the number of finished lubrication cycles ①, divider monitoring status ②, grease level status ③, counting down pause time ④ and counting upwards lube time ⑤. If a failure is detected by the controller, the display shows the Error Code instead of pause time or lube time in main display area.

Error Code:

- EE-1 Low grease level or no grease in pump reservoir, pump is under risk of empty running
- EE-2 Divider monitoring status - "Failure", pump is under risk of over pressure

Very Important! - The controller has Fault Tolerance Program; the error code only starts during the second cycle after the controller gets a failure signal. After the failure has been fixed, the controller needs 2 cycles as well to reset the failure signal automatically.



















Functional keys area: can adjust the pump parameters which shows on main display area, reset the lubrication cycle and clear the warning alarm.

Parameter Setting - Definition

Pos.	Parameter Description	Adjustable Range / Unit
1P	Pause Time	0 to 99 hrs and 0 to 59 mins Min. 1 min / Max. 99 hrs and 59 mins
2P	Divider Monitoring - Impulse cycles	0 to 99 impulses cycles 0 means system does not detect the impulse
3P	Lube Time	0 to 99 mins and 0 to 59 secs Min. 1 sec / Max. 99 mins and 59 secs
4P	Low Temperature setup	From -50 to 0 Celsius Degrees adjustable

LED Display AK06 with Integrated Controller AK09

Function and Display

Pos.	Sign	Description
1	Count 	Cycles Counting: During the pause time 1P, POS. 1 shows the number of finished lubrication cycles. The value of Count adds 1 after a full lube time. E.g., Count 168 means the system finished 168 lubrication cycles.
2	 Pressure	Divider Monitoring: During the running time 3P, 2 shows the impulse of the divider monitoring. OFF Pressure means controller is counting the detected impulse cycles from the divider monitoring. The Sign turns into ON Pressue after the preset value of impulse cycles from the divider has been detected. Main display turns into EE-2 , and you can hear an alarm for 30 seconds, if the controller has not detected the preset value of impulse cycles during the lube time.
3		Grease Level:  Grease level - Full. Pump grease level is above the minimum level, the pump will work under normal status according to the preset configuration.  Grease level - warning. Pump works under the risk of low grease level. An immediate grease refilling is recommended here.  Grease level - low. Pump detected low grease level status. During the automatic cycle, the pump stops immediately no matter it reaches the preset running time or not. Error EE-1 will appear on the monitor until the pump is refilled. Push  to clear the warning alarm. Special conditions: If after the initial alarm, the pump is manually started by pressing the R button from the display, then the pump will do a complete greasing cycle according to the value set at 3P setting. The alarm for EE-1 will engage after the cycle finishes. If the pump is manually restarted using the test button, the consequence will be followed same as automatic cycle.
4	Pause 	Pause Time: During the system pause time 1P, the main display shows e.g., ^{Pause} 10:28 for the remained actual pause time - 10 hours and 28 minutes and the time continue counting down to 00:00 and switch automatically to lube time.
5	 ^{Running}	Lube Time: During the system lube time, the main display shows e.g., 01:28 ^{Running} for the actual finished lube time – 1 minute and 28 seconds and the time continue counting upwards till the preset lube time then switch automatically to pause time.
6		Reset button (Test button): Push  during the pause time, main display stops counting down the remained pause time immediately and starts a new cycle with preset lube time. Push  during the lube time, main display stops counting lube time immediately and starts a new cycle with preset pause time.
7		Setting „Enter“ button / Warning alarm clear button: For „Enter“ function, please check the details in parameter setting. Push  during the system warning or error alarm (EE-1 or EE-2) to clear the alarm.
8		Parameter setting +: Please check the details in parameter setting.
9		Parameter setting „-“: Please check the details in parameter setting. Click Down Arrow no matter during the pause time or lube time, can enter the status checking interface to check the following data: D-XX: Program Code of the pump (for ALP81 Pump regular program, XX=56) EE-X: Error Code in the last cycle X (X= 0, 1, 2) t XX: Environment Temperature is XX°C -XX: Total Cycles is XX
10	Version: AK06	Controller Version: For internal controller, AK06 is the standard version. *For more details external controller please contact us.

LED Display AK06 with Integrated Controller AK09

Parameter Setting – First connecting to power

For first time connecting the power on the pump, the display shows the program code “d-56” up like *Dia. 23.1* or other pump pre-set program code, depends on pump and software type.

The program code can NOT be changed! The controller has pre-set parameters which can be changed under needs by following the setup steps. Otherwise, the pump runs with the default pre-set parameter.

After program code “d-56” the controller shows 1P Pause Time and is counting down, system cycle is 0 (*Dia. 23.2*).

Parameter Setting – Setup new parameter

Press Δ and ∇ button together with two fingers at the same time over 4 seconds, then release and press E to enter Parameter Editing Mode.

Press Δ or ∇ button to adjust the 1P Pause Time value for hour (*Dia. 23.3*). Then press E button again to enter -1 (Pause Time minute parameter) setting. Press Δ or ∇ button to adjust the -1 value for minutes (*Dia. 23.4*)*.

** 1P and -1 can not set as 00 in the same time. If 1P is set as 00, -1 starts with 01.*

Press E button to switch to 2P divider monitoring parameter setting - impulse cycles from 0 to 99. (*Dia. 23.5*)*.

** For system without divider monitoring sensor (proximity switch), set 2P always as 0.*

Press E button to switch to 3P Lubricating Time setting. 3P in minutes and -3 in seconds (the same way of setting the parameters we describe for 1P Pause Time and -1 setting) (*Dia. 23.6* and *Dia. 23.7*)*.

** 3P and -3 can not set as 00 at the same time. If 3P is set as 00, -3 starts with 01.*

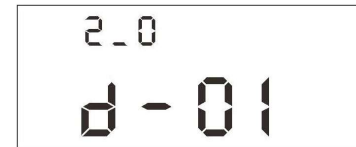

Dia. 23.1 Controller program code



Dia. 23.2 "Pause time" display after first power connection



Dia. 23.3 Setting of 1P - Pause Time in Hour



Dia. 23.4 Setting of 1P - Pause Time in Minute



Dia. 23.5 Setting of 2P - Impulse cycles



Dia. 23.6 Setting of 3P - Lube Time in Minute



Dia. 23.7 Setting of 3P - Lube Time in Second

LED Display AK06 with Integrated Controller AK09

Parameter Setting – Setup new parameter

Press **Ⓜ** button to switch to 4P Low temperature setting. With this parameter you can stop the pump working at low temperatures. Pre-set temperature is – 15° C. Press **△** or **▽** button to adjust the 4P low temperature setup. Press **Ⓜ** button to confirm your new low temperature setting (Dia. 24.1)*.

* **System has a temperature sensor. In case the real temperature is under the pre-set value, the pump stops automatically to avoid the damage of motor.**

Push **Ⓜ** to quit editing mode New parameter setting is done!

Display of controller during lubrication cycles

During 1P Pause Time - e.g., ^{Pause} 10:28, means pause time is 10 hours and 28 minutes. The Pause time is counting down wards in hours and minutes till 00:00 (Dia. 24.2), then 3P Lube Time starts counting upwards.

During 3P Lube Time -The 3P Lube Time starts counting upwards in minutes and seconds. E.g., 01:28^{Running}, you set up 1 min and 28 seconds as lube time. it is counting upwards from 0 sec to 01 min 28 seconds (Dia. 24.3).

A complete lubrication cycles = 1 full pause time + 1 full lube time, only after a complete lubrication cycle, the count of cycles +1 on pos. 1 in Dia. 21.1.

Reset of lubrication cycle

Push **Ⓜ** during the pause time, main display stops counting down the remained pause time immediately and starts a new cycle with pre-set lube time (Dia. 24.4).

Push **Ⓜ** during the lube time, main display stops counting lube time immediately and starts a new cycle with pre-set pause time. (Dia. 24.5)

Push **Ⓜ** always means skipping the current pause/lube time and enter into a new lube/pause time.



Dia. 24.1 Setting of 4P - Low Temperature



Dia. 24.2 Display for counting down Pause time 1P

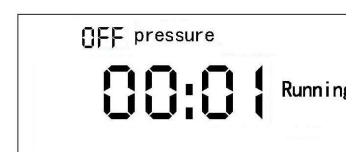

Dia. 24.3 Display for counting up Lube time 3P

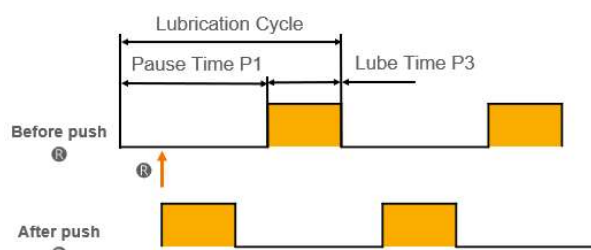

Dia. 24.4 Cycle changing when push **Ⓜ during Pause time**



Dia. 24.5 Cycle changing when push **Ⓜ during Lube time**

LED Display AK06 with Integrated Controller AK09

Restart of controller by switching off the machine

In case power/machine is switched off during a lube time P1 or pause time P3 following happens:

Switching machine on during 1P Pause Time, the 1P Pause time is counting down from the rest pause time where the machine was switched off (Dia. 25.1).

In case power / machine is switched off during a 3P Lubrication Time, the Lubrication time starts the full new Lubrication time which you setup (Dia. 25.2).

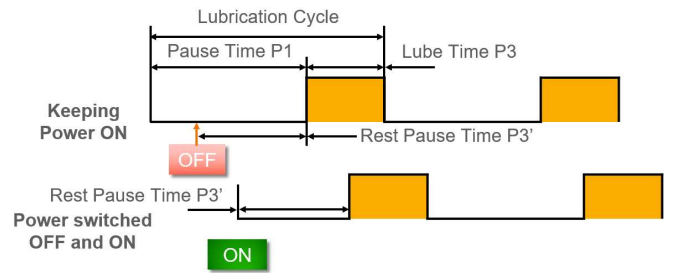

Dia. 25.1 Cycle changing when power switch ON and OFF during Pause time

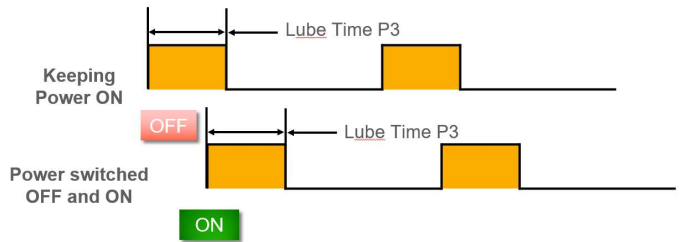

Dia. 25.2 Cycle changing when power switch ON and OFF during Lube time

More information for 2P – Impulse cycles setting with cycles sensor

2P divider monitoring, impulse cycles sensor on the divider, 2P can NOT be set as 0.

In case, the Detecting time T1, which is needed to detect the pre-set value of impulse cycles, is shorter than pre-set lube time 3P, Display turns from “OFF Pressure” to “ON Pressure” at the end of T1, Controller continues the rest lube time. After the lube time is finished, count of lubrication cycles +1. (Dia. 25.3).

In case the theoretical Detecting time T1, which is needed to detect the pre-set value of impulse cycles, is longer than pre-set lube time 3P, Display remains “OFF Pressure”, and shows EE-2 error message in the end of 3P and lasts for 30 secs. Lubrication cycles will not be counted. (Dia. 25.4).

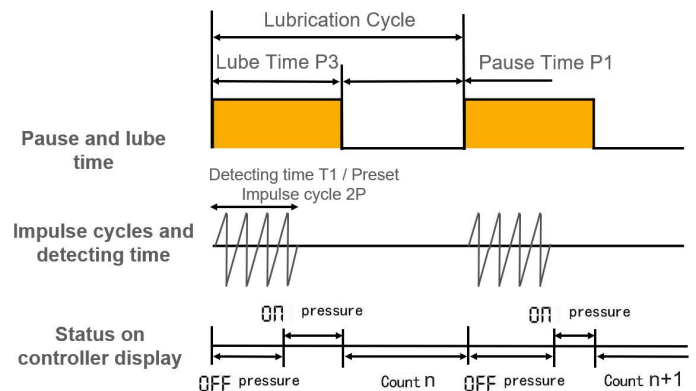

Dia. 25.3 T1 < 3P

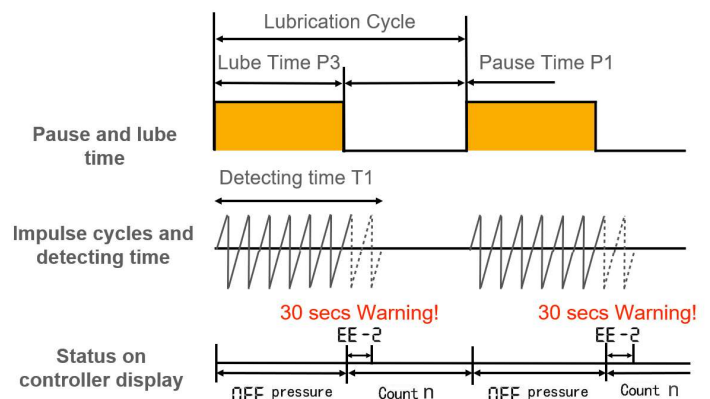

Dia. 25.4 T1 > 3P

For preset value of 3P - lube time less than 5 mins, the preset value of 2P less than 3 is recommended.

For preset value of 3P - lube time less than 10 mins, the preset value of 2P less than 5 is recommended.

The volume of grease for each greasing point only decided by 3P - lube time, not by 2P - impulse cycles.



Wiring Connection (With integrated Setting adjustable Controller AK09 V5.3)

ALPB BYN pump with 1 x BYN 7 pin connector + 1 x BD 4 pin connector – Solution for Divider Monitoring and External Test Button and Indication Light *

The power is supplied to 12 or 24V DC motor of pump via the BYN 7 pin connector from Pos. A, with an intermediate lubrication "Reset" function can be triggered by pressing a test button which is installed externally of the pump. During the lube time - 3P, test button lights "green". Button turns on "red" when the pump gets an error signal (Error code on Page 21). Button turns on "yellow" when a Reset cycle is trigged under error status.

Via Pos. B the divider monitoring 2P (proximity switch) is connected to the pump by an BD 4 pin connector.

* **For more information about other solutions please contact us.**

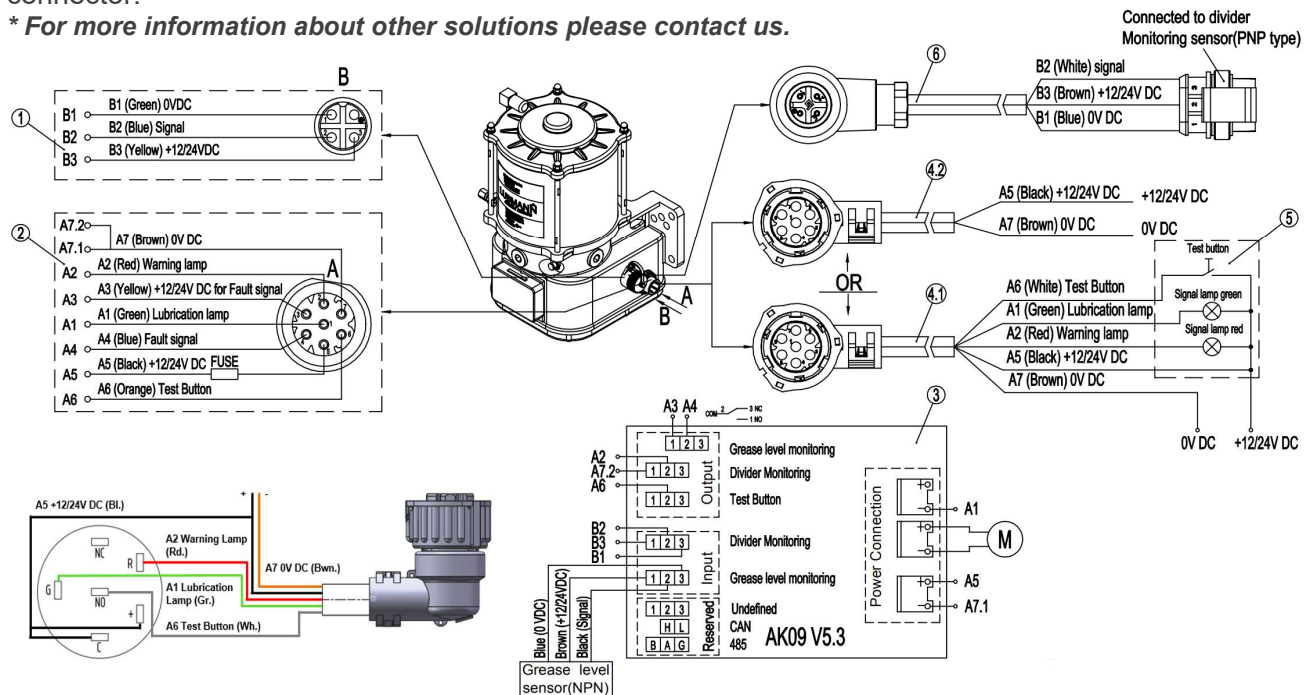

* In Dia. 26.1, it shows the pin connection for test button and indication light with Part No. 3030600350 or 3030600340. For test button and indication light with Part No.3030600200 or 3030600220 need A1, A5 and A6. For warning light with Part No. 3030102930 or 3030102940 need A1 and A2. More details for the pin connection on test button and light please check the accessories catalogue.

Dia. 26.1 Wiring Diagram for ALPB BYN controller version

Pos.	Qty.	Description	Part No.
1	1	Wire kit-divider monitoring-12/24VDC-int.-0,3m-BD_F_4P-3xP_JSTxH_F-3x0,5	2010821300
2A	0-1	Wire kit-power supply-ALPB_BYN-12VDC-Int.-0,3m-BYN_M_7P-5xP_JSTxH_F-2xP_JSTvH_F-7x0,5	2040120780
2B	0-1	Wire kit-power supply-ALPB_BYN-24VDC-Int.-0,3m-BYN_M_7P-5xP_JSTxH_F-2xP_JSTvH_F-7x0,5	2040120760
3	1	Controller-AK09-V5.3-programmable (print board)-program code d-56	2040120790
4.1	1	Cable kit-power supply-12/24VDC-Ext.-7,5m-BYN-elbow connector-7 Pin-5x1,0	2110012451
4.2	1	Cable kit-power supply-12/24VDC-Ext.-7,5m-BYN-elbow connector-7 Pin-2x1,0	2110012722
5A.1	0-1	Illuminated push button-24VDC-green-M16	3030600200
5A.2	0-1	Illuminated push button-12VDC-green-M16	3030600220
5B.1	0-1	Indication light-24VDC-red-M16	3030102930
5B.2	0-1	Indication light-12VDC-red-M16	3030102940
5C.1	0-1	Illuminated push button-24VDC-green_red_yellow-M16	3030600350
5C.2	0-1	Illuminated push button-12VDC-green_red_yellow-M16	3030600340
6	0-1	Cable kit-divider monitoring-12/24VDC-Ext.-7,5m-BD_M_90_4P-APM_F_3P-3x0,5	2110012409

Wiring Connection (With non-Controller AK09 WK2.0)

ALPB BYN pump with 1 x BYN 7 pin connector + 1 x BD 4 pin connector – Solution for External Indication Light *

The pump is supplied with 12/24V DC via the BYN 7-pin plug via Pos. A and the pump is not setting adjustable with lube time and pause time but controlled by power supply or external controller. The grease level indication light turns on “red” when the pump gets an error signal for the grease level.

For the non-controller version ALPB pump, it is **NOT** possible to monitor the divider status!

* **For more information about other solutions please contact us.**

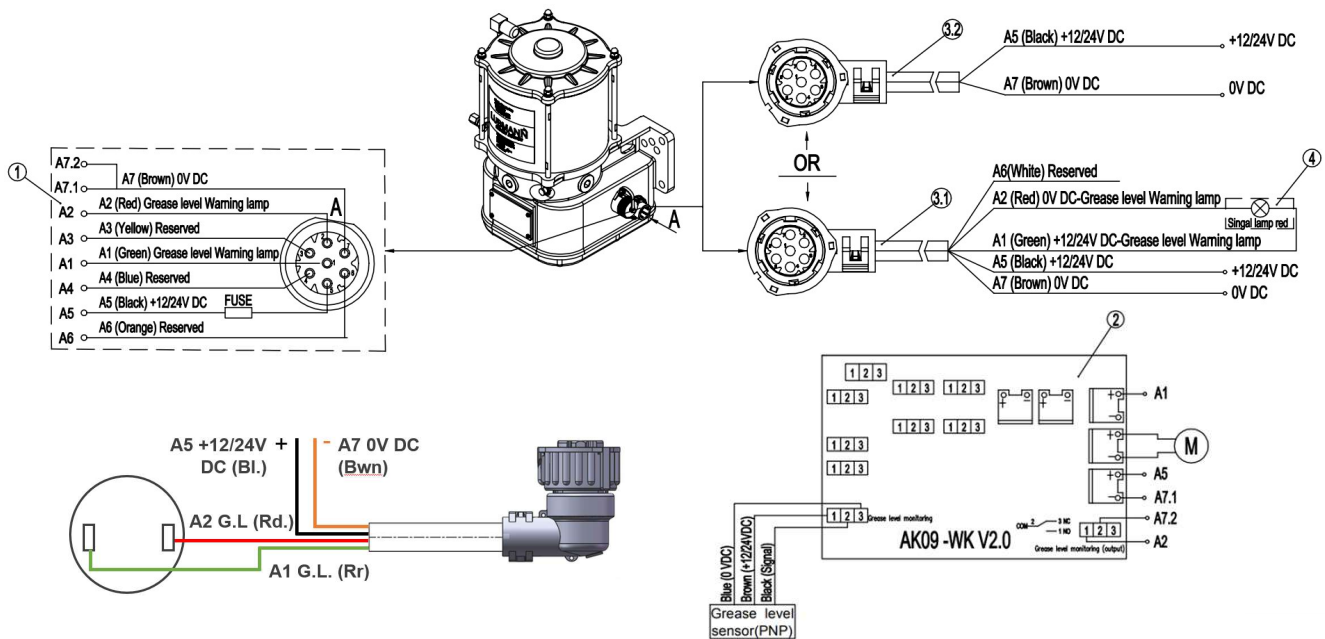

* In Dia. 27.1, it shows the pin connection for test button and indication light with Part No. 3030102930 or 3030102940.

Dia. 27.1 Wiring Diagram for ALPB BYN non-controller version

Pos.	Qty.	Description	Part No.
1A	0-1	Wire kit-power supply-ALPB_BYN-12VDC-Int.-0,3m-BYN_M_7P-5xP_JSTxH_F-2xP_JSTvH_F-7x0,5	2040120780
1B	0-1	Wire kit-power supply-ALPB_BYN-24VDC-Int.-0,3m-BYN_M_7P-5xP_JSTxH_F-2xP_JSTvH_F-7x0,5	2040120760
2A	0-1	Controller-AK09-WK-V2.0-12VDC-not programmable	2091000242
2B	0-1	Controller-AK09-WK-V2.0-24VDC-not programmable	2090122140
3.1	0-1	Cable kit-power supply-12/24VDC-Ext.-7,5m-BYN-elbow connector-7 Pin-5x1,0	2110012451
3.2	0-1	Cable kit-power supply-12/24VDC-Ext.-7,5m-BYN-elbow connector-7 Pin-2x1,0	2110012722
4.1	0-1	Indication light-24VDC-red-M16	3030102930
4.2	0-1	Indication light-12VDC-red-M16	3030102940

Filling of the Pump

1. Only use EP-2 lubricating greases that are approved for the various operating temperatures.
2. Keep the pump being vertical during the filling process.
3. When refilling the pump, the marking for the maximum filling level must not be exceeded. Check the filling process and complete it in time before the maximum fill level indicator is reached.
4. It is strictly forbidden to remove the top cover of the pump for filling lubricants!
5. Only fill in clean lubricants! The service life of the pump elements highly depends on the quality of the used lubricants.

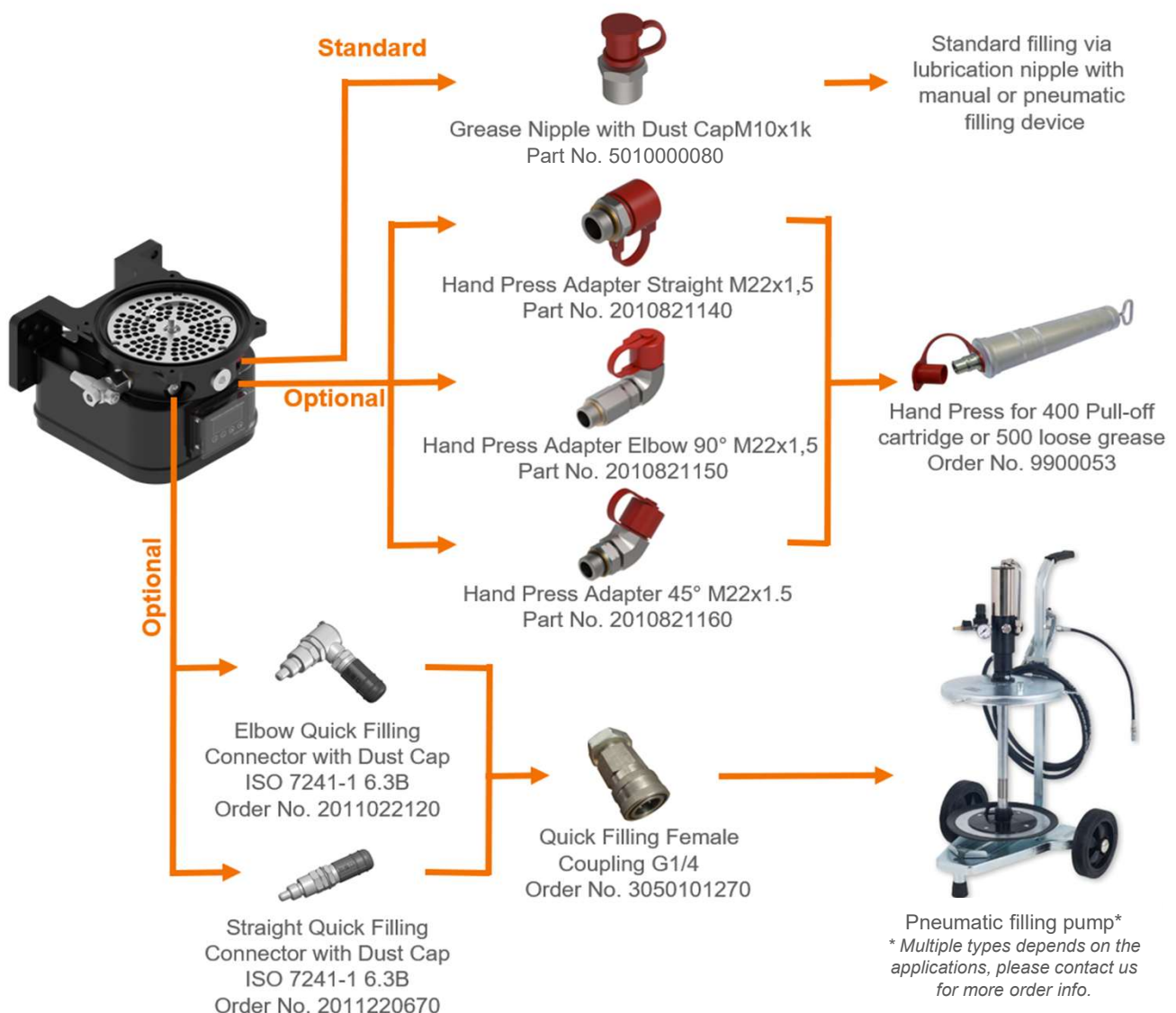

Dia. 28.1 Optional refilling devices for ALPB Pump

Explosion Drawing – ALPB Pump Body BYN + 2 - 6 Liter D170 Reservoir

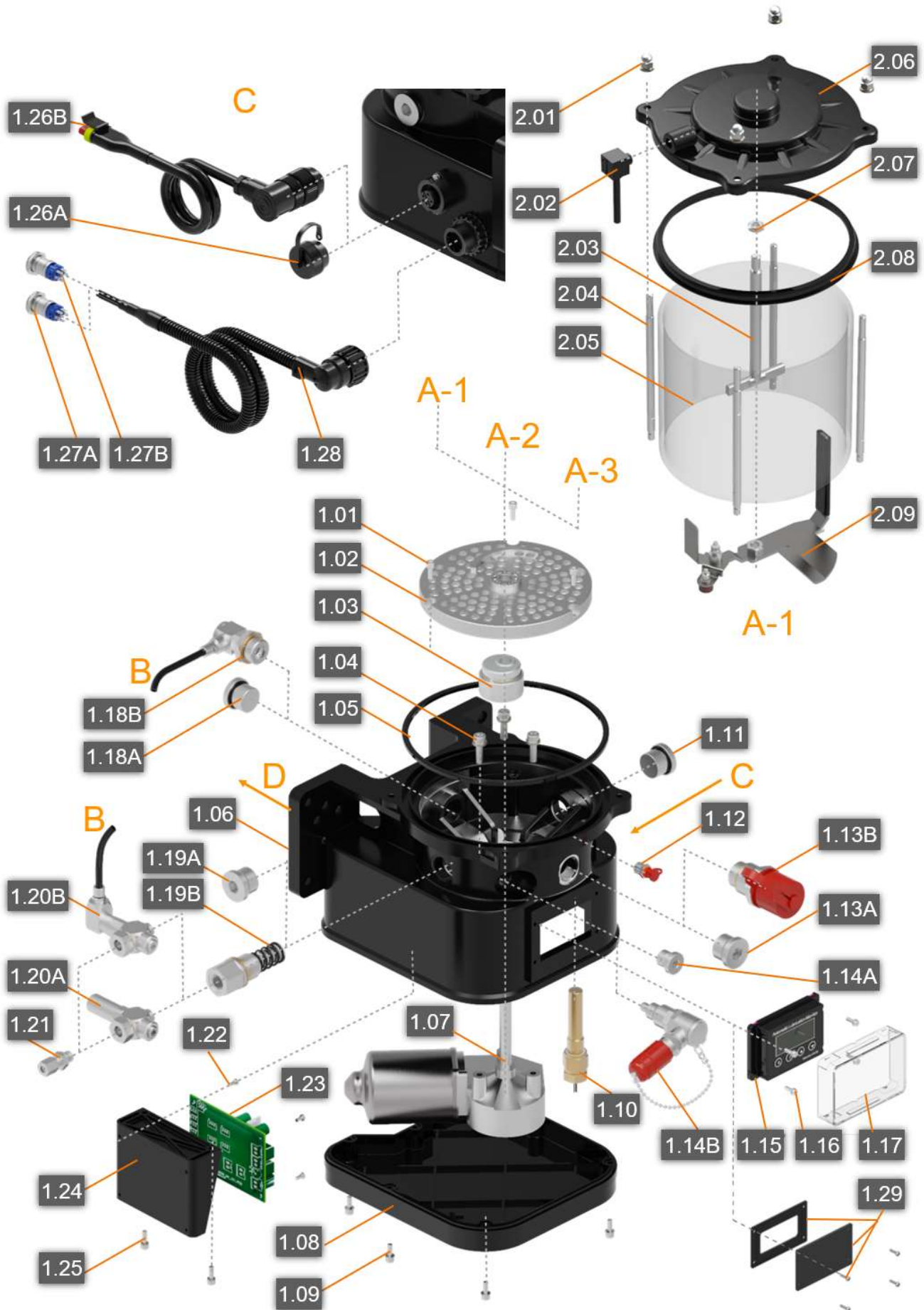

ALPB BYN VERSION PROGRESSIVE PUMP

Explosion Drawing: ALPB 8 – 20 Liter D230 Reservoir

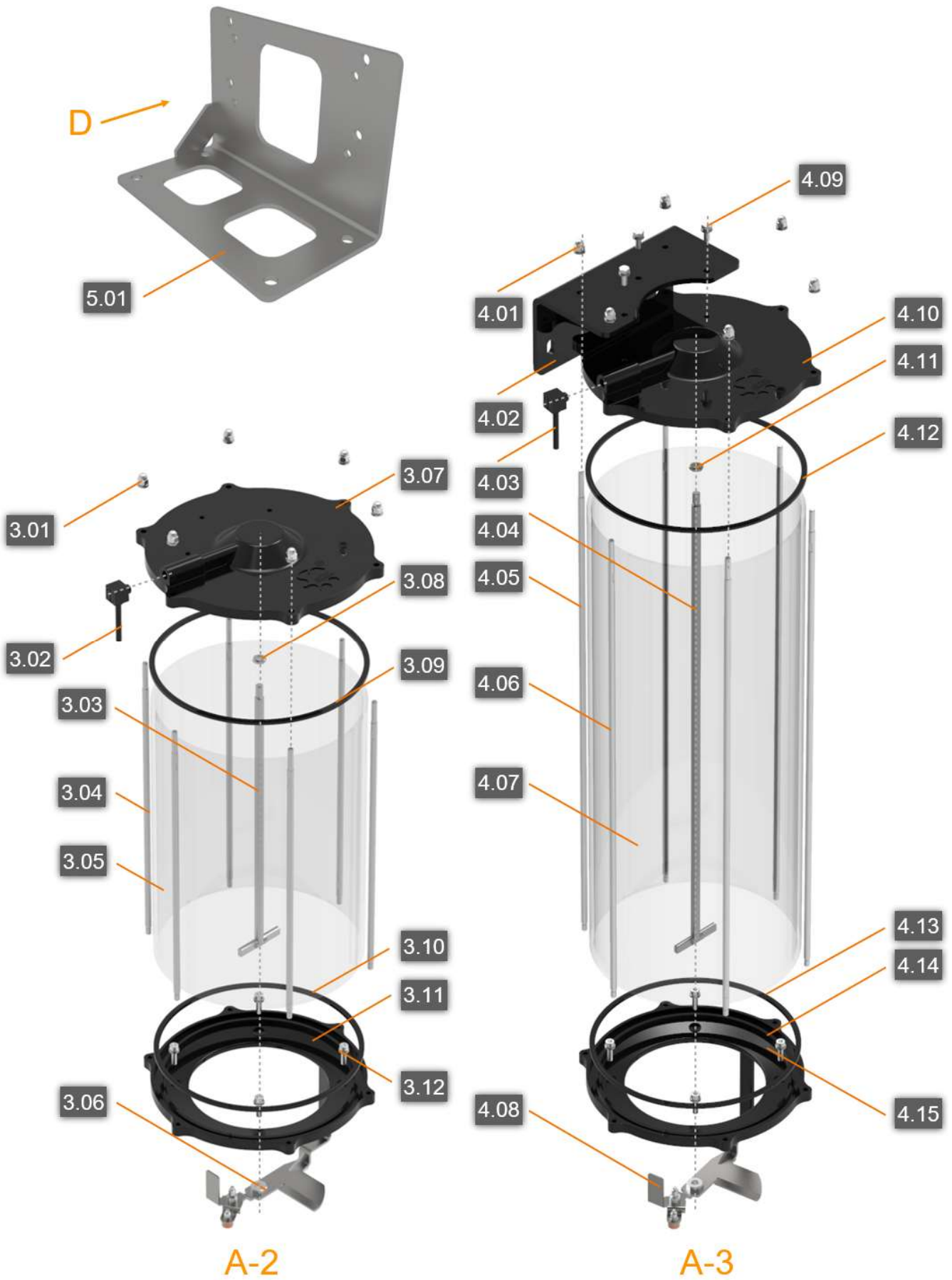

ALPB BYN VERSION PROGRESSIVE PUMP

General BOM - ALPB Pump Body

Pos.	Qty.	Description	Part No.
1.01	3	Hexagon socket head cap screw-DIN_EN_ISO_4762-M4x12-8.8-ST-ZnNi-including flat- and spring washer	3040102800
1.02-1	1	Perforated base plate-ALPB-D142x12-ST	2011230610
1.02-2	1	Bearing D10-26-H8	3049000630
1.03	1	Eccentric Unit-EDS-D37	2011223160
1.04-1	3	Hexagon socket head cap screw-DIN_EN_ISO_4762-M6x25-A2-SS	3040102100
1.04-2	3	Flat washer with rubber sealing lip D6	3040200830
1.05	1	Sealing ring-grease reservoir bottom-ALPB-D170-170x160x3-NBR	3020200220
1.06	1	Pump body housing for grease lubrication pump-ALPB-BYN-AI-black painted	2011031830
1.07A	0-1	Direct current motor-12V/DC-CNLW	3010404000
1.07B	0-1	Direct current motor-24V/DC-CNLW	3010404170
1.08-1	1	Kit-pump body cover-ALPB-201x180x23,5-with sealing, screws and washers* (incl. 1.08-2 and 1.09)	9901806
1.08-2	1	Sealing ring-pump body cover-ALPB-201x180-NBR	3020200420
1.09	7	Hexagon socket head cap screw-DIN_EN_ISO_4762-M4x20-A2-SS-including flat- and spring washer	3040104370
1.10A	0-1	Min. level sensor-ALPB-12V-24V/DC-NPN-M14x1,5	2090120730
1.10B	0-1	Min. level sensor-ALPB-12V-24V/DC-PNP-M14x1,5	2090122240
1.11	1	Screw plug-M22x1,5-(ED)-ST-ZnNi	3050105140
1.12	1	Grease nipple-M10x1-SS	5010000080
1.13A	0-1	Screw plug-M22x1,5-(ED)-ST-ZnNi	3050105140
1.13B	0-1	Filling connector-straight-M22x1,5-with dust cap-for Hand filling press	2010821140
1.14A	0-1	Screw plug-M14x1,5-(ED)-ST-ZnNi	3050101760
1.14B	0-1	Filling connector-swivel-ISO 7241-1B-M14x1,5-with dust cap	2011022120
1.15	0-1	LED-Display-AK06-(only display without controller)	2011223180
1.16	4	Cross recessed cheese head screw-M3x10-A2-SS-including flat- and spring washer	3040103720
1.17	1	LED-Display-AK06-transparent protective cover-85x60x19	3020102130
1.18A	0-1	Screw plug-M22x1,5-(ED)-ST-ZnNi	3050105140
1.18B	0-1	Kit-Single bypass for safety valve SV-A-M22x1,5	2011222820
1.19A	0-1	Screw plug-M22x1,5-(ED)-ST-ZnNi	3050105140
1.19B-A	0-1	Pump element-PE-1,5cm ³ /min-M22x1,5	2070011689
1.19B-B	0-1	Pump element-PE-2,5cm ³ /min-M22x1,5	2070011690
1.19B-C	0-1	Pump element-PE-4,5cm ³ /min-M22x1,5	2070011691
1.20A	0-1	Safety valve SV-C-preset to 300bar-G1/4-M10x1	2070011684
1.20B	0-1	Safety valve SV-A-preset to 300bar-G1/4-M10x1	2011221370
1.21	1	Straight screw coupling-GE-D6LL-M10x1 (SW14-ED)-ST-ZnNi	3050100890
1.22	4	Cross recessed cheese head screw-M3x6-A2-SS	3040101630
1.23A	0-1	Controller-AK09-V5.3-programmable (print board)-program code d-56	2040120790
1.23B	0-1	Controller-AK09-WK-2.0-24VDC-not programmable	2090122140
1.23C	0-1	Controller-AK09-WK-2.0-12VDC-not programmable	2091000242
1.24	1	Fixing bracket (internal) for controller-AK09-95x72x33	3020101210
1.25	2	Hexagon socket head cap screw-DIN_EN_ISO_4762-M4x10-A2-SS-including flat- and spring washer	3040102910
1.26A	0-1	Protective cap divider monitoring at pump-BD-4 pin-IP67	3030502160
1.26B-A	0-1	Cable kit-divider monitoring-12/24VDC-Ext.-7,5m-BD_M_90_4P-APM_F_3P-3x0,5	2110012409
1.26B-B	0-1	Cable kit-divider monitoring-12/24VDC-Ext.-5,0m-BD_M_90_4P-APM_F_3P-3x0,5	2110012410
1.27A-A	0-1	Illuminated push button-24VDC-green-M16	3030600200
1.27A-B	0-1	Illuminated push button-12VDC-green-M16	3030600220
1.27B-A	0-1	Indication light-24VDC-red-M16	3030102930
1.27B-B	0-1	Indication light-12VDC-red-M16	3030102940
1.27C-A	0-1	Illuminated push button-24VDC-green_red_yellow-M16	3030600350
1.27C-B	0-1	Illuminated push button-12VDC-green_red_yellow-M16	3030600340
1.28-A	0-1	Cable kit-power supply-12/24VDC-Ext.-7,5m-BYN-elbow connector-7 Pin-5x1,0	2110012451
1.28-B	0-1	Cable kit-power supply-12/24VDC-Ext.-5,0m-BYN-elbow connector-7 Pin-5x1,0	2110012452
1.29	0-1	Kit-blind plate with screws and washers-for without LED-Display-AK06	2090100780

General BOM - ALPB Reservoir Kit - 1

Pos.	Qty.	Description	Part No.
2.00A	0-1	Kit-grease reservoir attached to pump body-ALPB-D170-2L-(full package) * (incl. 2.01-2.09)	2011025480
2.00A-1	0-1	Kit-grease reservoir change-ALPB-D170-2L * (incl. 1.05, 2.03A, 2.04A, 2.05A, 2.08)	9901669
2.00B	0-1	Kit-grease reservoir attached to pump body-ALPB-D170-4L-(full package) * (incl. 2.01-2.09)	2011025490
2.00B-1	0-1	Kit-grease reservoir change-ALPB-D170-4L * (incl. 1.05, 2.03B, 2.04B, 2.05B, 2.08)	9901670
2.00C	0-1	Kit-grease reservoir attached to pump body-ALPB-D170-6L-(full package) * (incl. 2.01-2.09)	2011025500
2.00C-1	0-1	Kit-grease reservoir change-ALPB-D170-6L * (incl. 1.05, 2.03C, 2.04C, 2.05C, 2.08)	9901671
2.01-1	4	Hexagon acorn nut-DIN_1587-M6-6_A2-SS	3040102200
2.01-2	4	Flat washer-6,5x11,7x1,5-(M6)-A2-SS	3040101080
2.01-3	4	Spring washer-6,3x9,5x1,75-(M6)-A2-SS	3040101090
2.02	1	Kit ventilation-grease reservoir-ALPB	2090121660
2.03A	0-1	T-rod for grease distribution at reservoir-ALPB-D170-2L-D10-L132-ST-ZnNi	3010105470
2.03B	0-1	T-rod for grease distribution at reservoir-ALPB-D170-4L-D10-L277-ST-ZnNi	3010104120
2.03C	0-1	T-rod for grease distribution at reservoir-ALPB-D170-6L-D10-L377-ST-ZnNi	3010104130
2.04A	0 or 4	Tie-rod for grease reservoir-ALPB-D170-2L-D7-M6-L161-ST-ZnNi	3010403060
2.04B	0 or 4	Tie-rod for grease reservoir-ALPB-D170-4L-D7-M6-L306-ST-ZnNi	3010403780
2.04C	0 or 4	Tie-rod for grease reservoir-ALPB-D170-6L-D7-M6-L406-ST-ZnNi	3010404020
2.05A	0-1	Grease reservoir-transparent-ALPB-D170-2L-L140	2011025120
2.05B	0-1	Grease reservoir-transparent-ALPB-D170-4L-L285	2011025110
2.05C	0-1	Grease reservoir-transparent-ALPB-D170-6L-L385	2011025100
2.06	1	Top cover-ALPB-D170-Al-black painted	3010403680
2.07	1	Low hexagon nut-DIN_EN_ISO_4035-M8-A2-SS	3040102510
2.08	1	Z-sealing ring-grease reservoir top-ALPB-D170-160x176,6x10-NBR	3020200730
2.09	1	Kit-agitator blade with stirring paddle, magnet and guide plate-ALPB-D170	2011025540
3.00	0-1	Kit-grease reservoir attached to pump body-ALPB-D230-8L-(full package) * (incl. 3.01-3.12)	2011223000
3.01-1	6	Hexagon acorn nut-DIN_1587-M6-6_A2-SS	3040102200
3.01-2	6	Flat washer-6,5x11,7x1,5-(M6)-A2-SS	3040101080
3.01-3	6	Spring washer-6,3x9,5x1,75-(M6)-A2-SS	3040101090
3.02	1	Kit ventilation-grease reservoir-ALPB	2090121660
3.03	1	T-rod for grease distribution at reservoir-ALPB-D230-8L-D10-L334-ST-ZnNi	3010104060
3.04	6	Tie-rod for grease reservoir-ALPB-D170-8L-D7-M6-L348-ST-ZnNi	3010403711
3.05	1	Grease reservoir-transparent-ALPB-D230-8L-L322	2011230250
3.06	1	Kit-agitator Blade with stirring paddle, magnet and guide plate-ALPB-D230	2011223130
3.07	1	Top cover-ALPB-D230-Al-black painted	2011430270
3.08	1	Low hexagon nut-DIN_EN_ISO_4035-M8-A2-SS	3040102510
3.09	1	Sealing ring-grease reservoir-ALPB-D230-232x220x3-NBR	3020200290
3.10	1	Sealing ring-grease reservoir-ALPB-D230-232x220x3-NBR	3020200290
3.11	1	Intermediate flange for grease reservoir-ALPB-D170-D230-240x22-Al-black painted	2011230510
3.12-1	4	Hexagon socket head cap screw-DIN_EN_ISO_4762-M6x20-A2-SS	3040102080
3.12-2	4	Flat washer with rubber sealing lip D6	3040200830
4.00A	0-1	Kit-grease reservoir attached to pump body-ALPB-D230-15L-(full package) *(incl. 4.01-4.15)	2011223010
4.00B	0-1	Kit-grease reservoir attached to pump body-ALPB-D230-20L-(full package) *(incl. 4.01-4.15)	2011223020
4.01-1	6	Hexagon acorn nut-DIN_1587-M6-6-A2-SS	3040102200
4.01-2	6	Flat washer-6,5x11,7x1,5-(M6)-A2-SS	3040101080
4.01-3	6	Spring washer-6,3x9,5x1,75-(M6)-A2-SS	3040101090
4.02	1	Mounting bracket-grease reservoir top cover-ALPB-D230-Al-black painted	2090121660

General BOM - ALPB Reservoir Kit - 2

Pos.	Qty.	Description	Part No.
4.03	1	Kit ventilation-grease reservoir-ALPB	2090121660
4.04A	0-1	T-rod for grease distribution at reservoir-ALPB-D230-15L-D10-L582-ST-ZnNi	3010404560
4.04B	0-1	T-rod for grease distribution at reservoir-ALPB-D230-20L-D10-L792-ST-ZnNi	3010404570
4.05A	0 or 4	Tie-rod for grease reservoir-ALPB-D230-15L-D7-M6-L595-ST-ZnNi-for without top cover bracket	3010403641
4.05B	0 or 4	Tie-rod for grease reservoir-ALPB-D230-20L-D7-M6-L805-ST-ZnNi-for without top cover bracket	3010404580
4.06A	0 or 2	Tie-rod for grease reservoir-ALPB-D230-15L-D7-M6-L601-ST-ZnNi-for with top cover bracket	3010403651
4.06B	0 or 2	Tie-rod for grease reservoir-ALPB-D230-20L-D7-M6-L811-ST-ZnNi-for with top cover bracket	3010404590
4.07A	0-1	Grease reservoir-transparent-ALPB-D230-15L-L427	2011230780
4.07B	0-1	Grease reservoir-transparent-ALPB-D230-20L-L570	2011230790
4.08	1	Kit-agitator Blade with stirring paddle, magnet and guide plate-ALPB-D230	2011223130
4.09-1	3	Hexagon head bolt-ISO_4017-M6x15-A2-SS	3040102050
4.09-2	3	Flat washer-6,5x11,7x1,5-(M6)-A2-SS	3040101080
4.09-3	3	Spring washer-6,3x9,5x1,75-(M6)-A2-SS	3040101090
4.10	1	Top cover-ALPB-D230-Al-black painted	2011430270
4.11	1	Low hexagon nut-DIN_EN_ISO_4035-M8-A2-SS	3040102510
4.12	1	Sealing ring-grease reservoir-ALPB-D230-232x220x3-NBR	3020200290
4.13	1	Sealing ring-grease reservoir-ALPB-D230-232x220x3-NBR	3020200290
4.14	1	Intermediate flange for grease reservoir-ALPB-D170-D230-240x22-Al-black painted	2011230510
4.15-1	4	Hexagon socket head cap screw-DIN_EN_ISO_4762-M6x20-8.8-ST-ZnNi	3040102080
4.15-2	4	Flat washer with rubber sealing lip D6	3040200830
5.01	1	Mounting bracket-grease lubrication pump-ALPB-with welded counter nut-275x150x190-ST-black painted	3010102772

Delivery, returns and storage

Delivery

After receipt of the shipment, check the shipment for damage and completeness according to the shipping documents. Immediately report any transport damages to the forwarding agent. Keep the packaging material until any discrepancies are resolved. During in-house transport ensure safe handling.

Returns

Clean all parts and pack them properly (i.e., following the regulations of the recipient country) before returning them. Protect the product against mechanical influences such as impacts. There are no restrictions for land, sea or air transport.

Storage

Lubmann products are subject to the following storage conditions:

- dry, dust- and vibration-free in closed premises
- no corrosive, aggressive materials at the place of storage (e. g. UV rays, ozone)
- protected against pests and animals (insects, rodents, etc.)
- possibly in the original product packaging
- shielded from nearby sources of heat and coldness
- in case of high temperature fluctuations or high humidity take adequate measures (e. g. heater) to prevent the formation of condensation water

Storage conditions for parts filled with lubricant

The conditions mentioned in the following will have to be adhered to when storing products filled with lubricant.

Storage period of up to 6 months

The filled products can be used without having to take further measures.

Step for Storage period from 6 to 18 months - Pump

1. Connect the pump electrically
2. Switch the pump on and let it run, e.g., by triggering an additional lubrication, until about 4 cc of lubricant will leak from each pump element
3. Switch the pump off and disconnect it from the electrical grid
4. Remove and dispose of leaked lubricant



Step for Storage period from 6 to 18 months - Divider

1. Remove all connection lines and closure screws
2. Connect the pump which has been filled with new lubrication grease suitable for the application purpose to the divider
3. Let the pump run until new lubricant leaks from the divider
4. Remove leaked lubricant
5. Reinstall closure screws and connection lines



Step for Storage period from 6 to 18 months - Hose

1. Dismantle preassembled hose
2. Ensure that both sides of the hose remain open
3. Fill hose with new lubricant

Storage period exceeding 18 months

To avoid dysfunctions, consult the manufacturer before commissioning. The general procedure to remove the old grease filling corresponds to that of a storage period from 6 to 18 months

Installation

General information

Only qualified technical personnel may install the products described in these Instructions. During assembly pay attention to the following:

- Other units must not be damaged by the assembly
- The product must not be installed within the range of moving parts
- The product must be installed at an adequate distance from sources of heat and coldness
- Observe the product's IP degree of protection
- Adhere to safety distances and legal prescriptions on assembly and prevention of accidents
- Possible existing visual monitoring devices, e.g. pressure gauges, MIN/MAX markings or piston detectors, must be clearly visible
- Observe prescriptions in chapter Technical data regarding the installation position

Place of installation

Protect the product against humidity, dust and vibrations and install it in an easily accessible position to facilitate other installation and maintenance works.

Mechanical connection

- Minimum assembly dimensions

Ensure sufficient space for maintenance work or for attachment of further components to build a centralized lubrication system to the pump by leaving a free space of at least 100 mm into each direction in addition to the stated dimensions.

**All the installation dimensions can be found on page 19.*

- Installation bores

Risk of damage to the superior machine and to the pump



Drill the mounting bores on non-loadbearing parts of the superior machine only. Fastening must not be done on two parts moving against one another (e. g. machine bed and machine assembly).

- Electrical connection

Electric shock



Make sure to disconnect the product from the power supply before carrying out any works on electrical components.

Carry out the electrical connection according to the connection type of the pump,

1. Tailor the line for the power supply according to the respective connection diagram in these instructions or use pre-fabricated cable. It is mandatory to use a backup fuse. Check on page 12!
2. In case the divider monitoring function is not needed on the pump, insert the BD protective cap 3030502160 into the BD socket and tighten it. Only by doing so the degree of protection (IP class) can be complied with.

- Mount pump element and safety valve

Generally, a standard pump has a set of pump element and safety valve (SV-C) on the left side of the pump outlet. To mounting an extra set of pump element and safety valve, please make sure, the pump has been disconnected from the power supply.

Tightening torque for pump element = 43 Nm +/- 2,0 Nm
Tightening torque for safety valve = 36 Nm +/- 2,0 Nm



Trouble shooting

Fault	Possible cause	Solution
Pump does not run	<ul style="list-style-type: none"> ▪ Power supply to pump interrupted <ul style="list-style-type: none"> – Superior machine is switched off – Connection cable of pump is loose or defective – External fuse is defective ▪ Pump is in the pause time mode ▪ Pump motor is defective ▪ Pump print board is defective ▪ Internal cable break 	<p>Check whether one of the indicated faults is present and remedy it in the frame of responsibilities.</p> <p>Faults outside of your own responsibility have to be reported to your superior to initiate further measures.</p> <p>If the fault cannot be determined and remedied, please contact our Customer Service</p>
Pump runs but supplies no or only little lubricant	<ul style="list-style-type: none"> ▪ Blockade, fault within the centralized lubrication system ▪ Grease level in reservoir under Min. level ▪ Defective non-retrun valve ▪ Defective safety valve ▪ Suction bore of pump element is clogged ▪ Close pump element ▪ Air bubbles in the pump body ▪ Too high lubricant consistency (at low temperatures) ▪ Too low lubricant consistency (at high temperatures) ▪ Wrong configuration of dividers 	<p>Check whether one of the indicated faults is present and remedy it in the frame of responsibilities.</p> <p>Faults outside of your own responsibility have to be reported to your superior to initiate further measures.</p> <p>If the fault cannot be determined and remedied, please contact our Customer Service</p>

* More details for EE-1 and EE-2 as the error code on pump display please check page 20 and 21.

Trouble shooting for the Blockade of a progressive pump

Possibilities for a blockade:

- Defect of pump element

Dismount the main hose from the pump and check the pressure of the manometer. The safety valve must open before the manometer reaches 250 - 300 bar.

If no manometer is available: dismount the inlet coupling in front of the main divider and check if grease is delivered.

- Defect motor / control unit

For pump with integrated controller, press the button "R" on the display and check if the motor rotates.

- Defect of the safety valve

Signal for a defected safety valve – the lubricant comes out from the safety valve.

Dismount the main hose from the outlet of the safety valve and use a blind plug on the outlet. Check the pressure of the manometer, if the safety valve opens under 180bar, replace the safety valve.

After all the above processes have been checked but no defects have been found, the further checking for the dividers need be done as well. more details for divider checking please check the trouble shooting of divider.

Important!



The repair work must be done under maximum cleanliness.

Shutdown and disposal



Temporary shutdown

Temporarily shut the system down by:

- Switching off the superior machine.
- Disconnecting the product from the power supply.

Final shutdown and disassembly

The final shutdown and disassembly of the product must be planned and carried out by the operator in a professional manner and in compliance with all regulations to be observed.

Disposal

- for Countries within the European Union

Disposal should be avoided or minimized wherever possible. Disposal of products contaminated with lubricant must be affected via licensed waste disposal contractor in accordance with environmental requirements and waste disposal regulations as well as local authority requirements.

The specific classification of the waste is in the waste producer's responsibility, as the European Waste Catalogue provides different waste disposal codes for the same type of waste but of different origin.

Electrical components have to be disposed of or recycled following WEEE directive 2012/19/EU.

Plastic or metal parts can be disposed of with the commercial waste.

- for Countries outside the European Union

The disposal must be done according to the valid national regulations and laws of the country where the product is used.

Order Key

ALPB - 2 . 2 . PE 2.5C - 0 - 0 - 0 . 2 . 0 . 1 . 0000

Power supply	
12V	1
24V	2

Size of grease reservoir (liter)	
2L D170	2
4L D170	4
4L D230	4W
6L D170	6
6L D230	6W
8L D230	8
15L D230	15
20L D230	20

Pump outlet M22x1.5 configuration - Pos. 1/2/3/4				
	Pos. 1	Pos. 2	Pos. 3	Pos. 4
Screw plug	0	0	0	0
PE 1.5 without bypass	1.5C	1.5C	1.5C	1.5C
PE 1.5 with bypass	1.5A	1.5A	1.5A	1.5A
PE 2.5 without bypass	2.5C	2.5C	2.5C	2.5C
PE 2.5 with bypass	2.5A	2.5A	2.5A	2.5A
PE 4.5 without bypass	4.5C	4.5C	4.5C	4.5C
PE 4.5 with bypass	4.5A	4.5A	4.5A	4.5A
Hand press adapter straight		HP	HP	
Hand press adapter 45°		HP45	HP45	
Hand press adapter 90°		HP90	HP90	
Bypass inlet *	BP	BP	BP	BP
Customised setting	X	X	X	X

Standard: PE at position 1

* For pump elements with a safety valve with bypass, a bypass inlet must be provided at the nearest outlet.

Pos. A - power connector	
without power cable	0
with cable kit-power supply BYN 5/7 Pin, 7,5 m	2
Customized version	X

Pos. B - Divider monitoring (Signal input)	
with protective cap divider monitoring	0
Customized version	X

Controller	
without controller	0
with standard integrated Controller AK06	1
Customized version	X

Special Models	
Standard Version	0000
Customized Version	XXXX

Pos. 1 Pos. 2 Pos. 3 Pos. 4

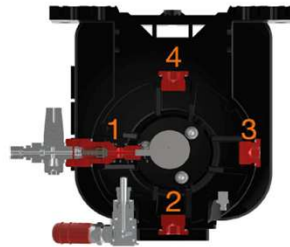

B A