

Operating- and assembly manual Progressive divider JPQ6_FKM

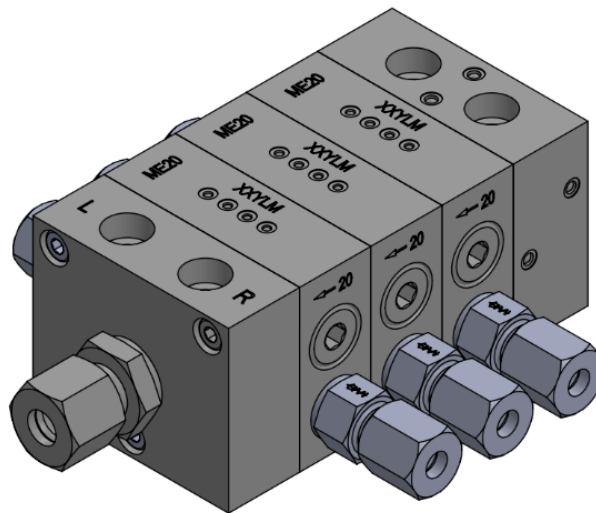

Contents

1	Declaration of incorporation.....	2
2	Imprint.....	3
3	Explanation of symbols	4
4	Warranty and extent of warranty	4
5	Safety instructions	4
6	Delivery, Returns and Storage	7
7	Shutdown and disposal	8
8	Accompanying documents.....	8
9	Technical Data.....	9
9.1	Data	9
9.2	Installation dimensions - Standard.....	9
9.3	Installation dimensions – with solenoid valve.....	10
10	Components	11
10.1	Divider elements	12
10.2	Tie rods.....	13
10.3	Bridge	14
10.4	Screw plug for divider outlet	14
10.5	Divider Accessories.....	15
10.5.1	Solenoid valve.....	15
10.5.2	Divider monitoring - Sensor	16
10.5.3	Divider monitoring - cables	17
11	Working principle.....	18
11.1	General.....	18
11.2	Operating principle	20
12	Commissioning / Assembly.....	22
13	Troubleshooting	23

All information subject to technical changes.

Rev.	Änderung	Date / Author	Date / Release
01	Extension – Technical data	17.12.2024 / HB	17.12.2024 / VH
02	Technical data updated	13.01.2025 / HB	13.01.2025 / VH
03	Example internally bridged	30.01.2025 / EB	30.01.2025 / VH
04	Declaration of incorporation added, page 12,13 and 18 updated	17.03.2025 / HB	17.03.2025 / VH
05	Material added	26.06.2025 / HB	26.06.2025 / VH
06	Operating principle 11.2 added	12.03.2026 / HB	16.03.2026 / VH

1 Declaration of incorporation



Declaration of incorporation for incomplete machinery (acc. to EC-directive 2006/42/EG)

The manufacturer: Lubmann GmbH, Kleiner Johannes 21, 91257, Pegnitz, Germany
declares hereby, that the following partly completed machinery:

Progressive divider
Type: JPQ6
Part No.: 20xxxxxxxx / 99xxxxx / 15xxxxxx

is complying with all essential requirements of the above-mentioned machinery directives
(2006/42/EG): Annex I, article 1.1.2, 1.1.3, 1.1.5, 1.3.2, 1.3.4, and 1.5.1.

The following coordinated standards have been used:
DIN EN 809
DIN EN ISO 12000

The following other specifications and standards have been used:
VDE 0530

The protection targets of the directive for have been electric equipment 2006/95/EG observed
according to the annex I, no. 1.5.1 of the machine directive.

The incomplete machine may only be put into service as soon as there has been stated that the
machine, into which the incomplete machine shall be installed, responds to the determinations of the
machine directive (2006/42/EG).

The special documentation that responds to the machine, has been prepared according to annex VII
part B.

The manufacturer, documentation department, phone +49 9241 80 89 87 00,
email: info@lubmann-gmbh.de; obliges itself to pass on electronically the special documentation for
partly completed machinery to individual national authorities upon request.

Pegnitz 0107.2024
Lubmann GmbH
Kleiner Johannes 21
D-91257 Pegnitz
www.lubmann-gmbh.de

ppa. Markus Kürzdörfer
General Manager
Lubmann GmbH

www.Lubmann-GmbH.de

Amtsgericht Bayreuth HRB-Nr. 7823 Steuernummer: DE316746274 Adresse: Kleiner Johannes 21, D-91257 Pegnitz Email: Info@lubmann.de

2 Imprint

Manufacturer

Lubmann GmbH
Add: Kleiner Johannes 21, 91257 Pegnitz, Germany
E-Mail: info@lubmann-gmbh.de
Website: www.lubmann-gmbh.de

Training courses

In order to provide a maximum of safety and economic viability, Lubmann GmbH carries out detailed training courses. It is recommended that the training courses are attended. For more information, please contact Lubmann GmbH.

Copyright

© Copyright Lubmann GmbH All rights reserved

Disclaimer

The manufacturer shall not be held responsible for damages caused by:

- Non appropriate use faulty assembly, operating, setting, maintenance, repair or accidents
- Use of inappropriate lubricants
- Improper or late response to malfunctions
- Unauthorized modifications of the product
- Intent or negligence
- Use of non-original Lubmann spare parts
- Faulty planning or layout of the centralized lubrication system

Liability for loss or damage resulting from the use of our products is limited to the maximum purchase price. Liability for consequential damages of whatever kind is excluded.

3 Explanation of symbols



Safety instructions which, if not complied with, may endanger persons, are marked specifically with the general hazard symbol!



This heading is used if inaccurate compliance or non-compliance with the Operating Instructions or specified work procedures etc. may result in damage.



General commandment!
Points out Special Information!

4 Warranty and extent of warranty

Inappropriate intervention will rule out your warranty claim!

Warranty regarding operational safety, reliability and performance of the progressive divider is only accepted by the manufacturer under the following conditions:

- Assembly, connection, setting, maintenance and repair are carried out by authorized and specialized staff.
- The limits stipulated in the technical data must never be exceeded
- Only original components or components approved by the manufacturer may be used for repair and maintenance work.

All guarantees and warranties expire for damages to the grease lubrication pump that are caused by operation with improper lubricants (e.g., piston wear, piston jamming, plug-ins, embrittled sealings). Lubmann does not assume liability on damages caused by lubricants, even if these lubricants have been tested and released by laboratory tests, as damages caused by lubricants (e.g., by expired or improper stored lubricants, batch variations etc.) can not be retraced to their root cause in retrospect.

Contact: Lubmann GmbH, Kleiner Johannes 21, 91257 Pegnitz, Germany

5 Safety instructions

General information

Any safety-related faults must be eliminated without delay.

Below please find fundamental instructions to be complied with, regarding assembly, operation and maintenance. The mechanical and the competent specialists / staff of the operating company must read the Operating Instructions on all accounts prior to starting assembly, commissioning and maintenance. Moreover, the Operating Instructions must permanently be available on site.

Not only the safety instructions included under this item, but also the specific safety instructions appearing in other parts of this manual must be complied with.

General risk reference

All system components have been designed in view of operational safety and accident prevention according to the applicable provisions for the design of technical equipment.

Nevertheless, utilization thereof may result in risks for the user or third parties and/or technical equipment. Thus, the system may only be used in proper technical working within its intended fields of application and in compliance with the safety provisions and the Operating Instructions.

Personal

The staff in charge of operation, maintenance, inspection and assembly must be qualified accordingly for this work. The operating company must stipulate competences, responsibilities and the supervision of staff precisely. If the staff does not dispose of the appropriate knowledge, they must be trained and instructed. The operating company must ensure that the staff have understood the contents of the Operating Instructions.

Danger due to non-observance of the safety information



Non-compliance with the safety information may put persons at risk and endanger the environment and/or the machine. Non compliance with the safety instructions may rule out any claims for damages.

Non-compliance may lead, e. g. to the following dangers:

- Failure of important system functions,
- Failure of the specified maintenance and servicing methods,
- Endangering people due to electrical, mechanical and chemical effects,
- Endangering the environment due to leakages of dangerous materials.

Use in conformity with the intended purpose:

The divider of the series JPQ6 serve only for supply of lubrication points or secondary dividers at vehicles, systems and machines.

Any use beyond this scope is regarded as being not in conformity with the intended purpose.

Assembly and maintenance

Observe for all assembly works at vehicles, systems and machines the valid local accident prevention regulations and safety instructions as well as the specifications for operation and maintenance.

All maintenance, inspection and assembly work may only be carried out by trained specialists. All work must only be carried out when the plant is at a standstill and while wearing appropriate protective clothing.

All the safety and protective equipment must be replaced immediately after completing work.



Media that endangers the environment must be disposed in accordance with pertinent official specifications.

Secure the system during maintenance and repair works, against intentional and unintentional reoperation.

Dispose of process materials in accordance with the safety data sheets of the lubricant manufacturer.

Safety information for operators/operating staff

If hot or cold machine parts led to hazards, the customer must secure them from being touched.

The guards on moving or rotating parts must not be removed.



Drain leakages of dangerous materials in a way, that people or the environment are not endangered.

Comply with legal regulations.

Exclude any hazards by electric energy.

Unauthorized modification and spare part production



Modifications and alterations of the system require the manufacturer's prior approval. Original spare parts and accessories authorized by the manufacturer serve for higher safety. The use of other parts may rule out liability for the consequences of such use. For components, which are retrofitted by the operator, Lubmann does not assume liability nor claims for compensation.

Danger caused by the electrics



The units may be connected to the power supply exclusively by appropriately trained qualified personal in conformity with the local connection conditions and regulation (e. g. DIN, VDE)!

Improperly connected equipment may lead to serious personal injury and damage to property!

Danger caused by system pressure



The units might be under pressure. Make them pressure less before you start with repairs, changes or extensions.

Use of hydraulic hose lines

Installing hydraulic hose lines at the divider, the operator must observe respectively ensure the following items. Checks for proper assembly and function must be carried out according to the regional valid guidelines.



Checks for a safe provisioning and use must be carried out according to the regional valid guidelines.

The check deadline must not be exceeded.

Exchange defect hydraulic hose lines immediately and professional.

Hydraulic hose lines subject to a wear process and must be exchanged regularly and according to the manufacturer`s details.

Cleaning



The progressive divider can be cleaned with a high-pressure cleaner.

If an optional divider monitoring sensor / solenoid valve is installed, it is not permitted to clean it with a high-pressure cleaner! The spray jet can cause water to penetrate the monitoring system via the seals.

In this case, Lubmann GmbH does not assume any warranty / guarantee!

Lubricant

The system has been designed for commercially available multi-purpose greases of NLGI class 2 for operation in summer and winter.

Use grease with high-pressure additives (EP greases).

Only use greases of the same saponification type.

Lubricants containing solid contents must not be used (lubricants like graphite or MoS₂ on request).



Observe the vehicle manufacturer`s specifications, when you select the lubricant.

After the system has been shut down, check the lubricant for physical and chemical signs of ageing to ensure that it is still suitable for use.

Observe the safety data sheet for the lubricant used.

Hazards to environment cause by lubricants

The lubricants which are recommended by the manufacturer of your vehicle, system or machine correspond in their composition to the common safety regulations. Mineral oils and greases are generally hazardous to ground water and their storage, processing and transport requires special precautions.,

Inadmissible methods of operation



Operational security of the plant is only guaranteed if it is operated in accordance with the operating instructions. The limit values stated in the technical data must not be exceeded under any circumstances.

6 Delivery, Returns and Storage

Delivery

The progressive dividers of the JPQ6 series are packaged according to standard commercial packaging in accordance with the regulations of the recipient country and wishes of the customer.

There are no restrictions for land, sea or air transport.

After receipt of the shipment, check the shipment for damage and completeness according to the shipping documents. Immediately report any transport damages to the forwarding agent. Keep the packaging material until any discrepancies are resolved. During in-house transport ensure safe handling.

Returns

Clean all parts and pack them properly (i.e., following the regulations of the recipient country) before returning them.

Protect the product against mechanical influences such as impacts.

There are no restrictions for land, sea or air transport.

Storage

Lubmann products are subject to the following storage conditions:

- dry, dust- and vibration-free in closed premises
- no corrosive, aggressive materials at the place of storage (e. g. UV rays, ozone)
- protect from environmental influences such as UV rays
- protected against pests and animals (insects, rodents, etc.)
- possibly in the original product packaging
- shielded from nearby sources of heat and coldness
- in case of high temperature fluctuations or high humidity take adequate measures (e. g. heater) to prevent the formation of condensation water

Storage conditions for parts filled with lubricant

The conditions mentioned in the following will have to be adhered to when storing products filled with lubricant.

Storage period of up to 6 months

The filled products can be used without having to take further measures.

Storage period from 6 to 18 months



1. Remove all connection lines and closure screws
2. Connect the pump which has been filled with new lubrication grease suitable for the application purpose to the divider
3. Let the pump run until new lubricant leaks from the divider
4. Remove leaking lubricant
5. Reinstall closure screws and connection lines

Storage period more than 18 months



To avoid dysfunctions, consult the manufacturer before commissioning. The general procedure to remove the old grease filling corresponds to that of a storage period from 6 to 18 months

7 Shutdown and disposal

Temporary shutdown

Temporarily shut the system down by:

- Switching off the superior machine.
- Disconnecting the product from the power supply.

Final shutdown and disassembly

The final shutdown and disassembly of the product must be planned and carried out by the operator in a professional manner and in compliance with all regulations to be observed.

Disposal

- for Countries within the European Union

Disposal should be avoided or minimized wherever possible. Disposal of products contaminated with lubricant must be affected via licensed waste disposal contractor in accordance with environmental requirements and waste disposal regulations as well as local authority requirements.



The specific classification of the waste is in the waste producer's responsibility, as the European Waste Catalogue provides different waste disposal codes for the same type of waste but of different origin.

Electrical components have to be disposed of or recycled following WEEE directive 2012/19/EU.

Plastic or metal parts can be disposed of with the commercial waste.

- for Countries outside the European Union



The disposal must be done according to the valid national regulations and laws of the country where the product is used

8 Accompanying documents

In addition to this manual, the following documents must be considered by the respective target audience:

- Operational instructions and release regulations for the pump used
- Safety data sheet for the lubricant used
- Project documentation
- Operating instructions for components installed during assembly of the central lubrication system
- Release regulations and regulations in the company

9 Technical Data

9.1 Data

Max. operating pressure:		300 bar
Min. number of middle elements:		3
Max. number of middle elements:		10
Inlet thread:		G 1/4
Outlet thread:		G 1/8
Material elements:		Steel AISI 12L14
Surface elements:		ZnNi
Induction switch nominal voltage:		10-30 V DC 200 mA
Lubricant:	Grease	max. NLGI - 2
	Oil	min. 30 mm ² / s
Temperature Range:		- 25°C to 80°C
Weight: (depends on customization)		1,5 to 9,0 kg

9.2 Installation dimensions - Standard

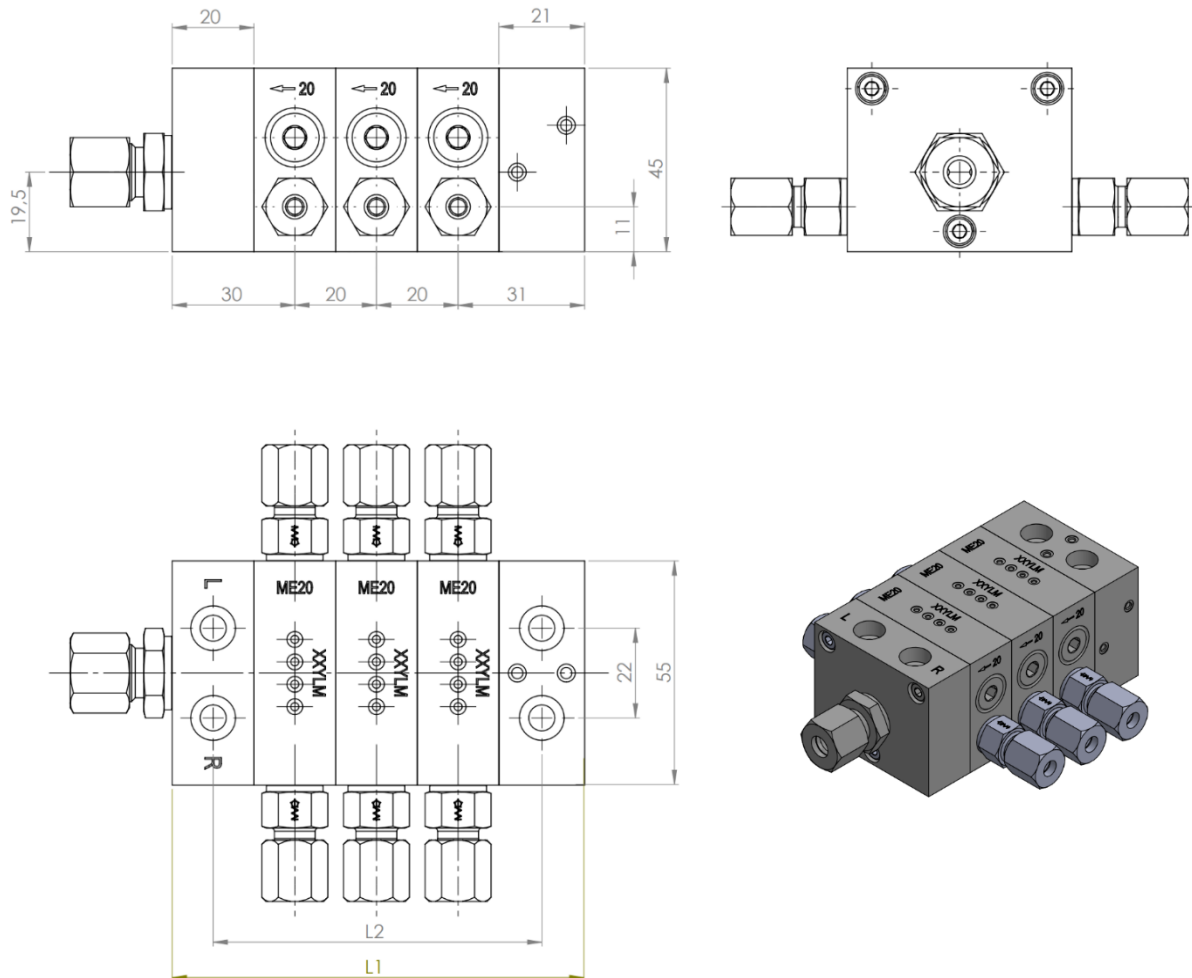

Number of middle elements	3	4	5	6	7	8	9	10
L1 [mm]	101	121	141	161	181	201	221	241
L2 [mm]	80,5	100,5	120,5	140,5	160,5	180,5	200,5	220,5

9.3 Installation dimensions – with solenoid valve

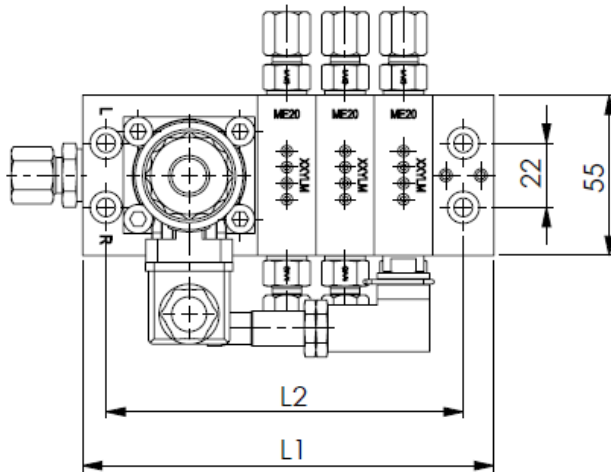
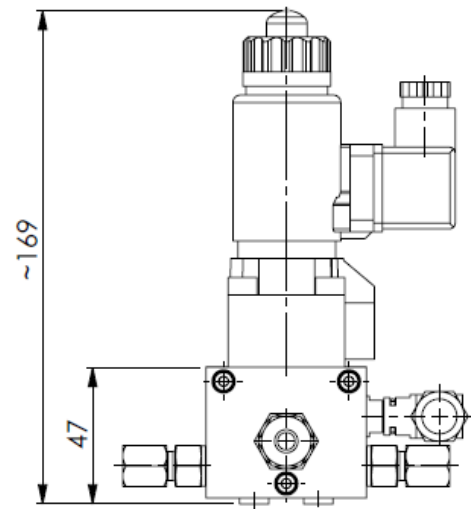
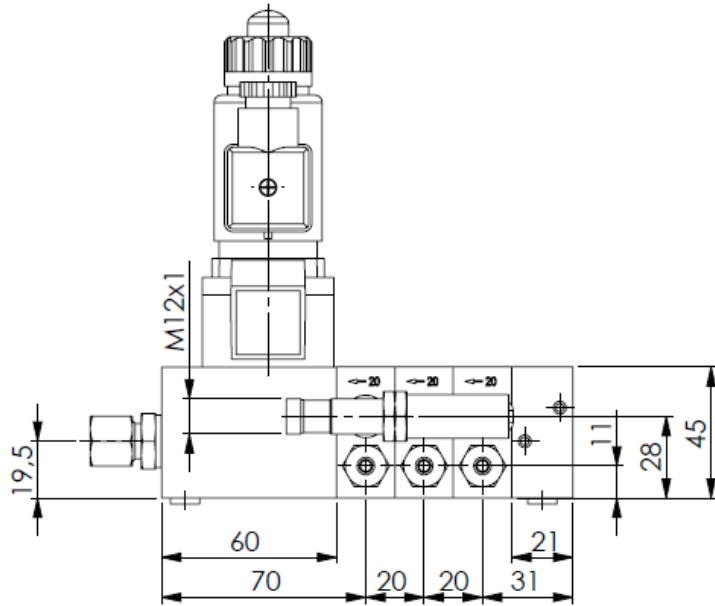

Number of middle elements	3	4	5	6	7	8	9	10
L1 [mm]	141	161	181	201	221	241	261	281
L2 [mm]	122,5	142,5	162,5	182,5	202,5	222,5	242,5	262,5

10 Components

The JPQ6 progressive divider consists of any 3 to 10 middle elements, a start and an end element.

We call the first element in the direction of the lubricant supply the starting element and the last in the row the end element.

Each element has a maximum of 2 exits, which are mounted horizontally on the side of the elements. In order to achieve the exact metering volume of different lubrication points, in some cases it is necessary to bridge the outputs of the divider internally or externally and to combine outputs. In this way, the dosage quantities of the individual divider elements can always be dosed appropriately for each lubrication point.

An arrow and the dosage number are stamped on the sides of the individual elements.

The output associated with each element is always located at the next element in the direction of the starting element.

The progressive divider can be equipped with monitoring (signal pin or contactless switch).

The progressive divider JPQ6 can be used either as a main divider or a secondary divider.

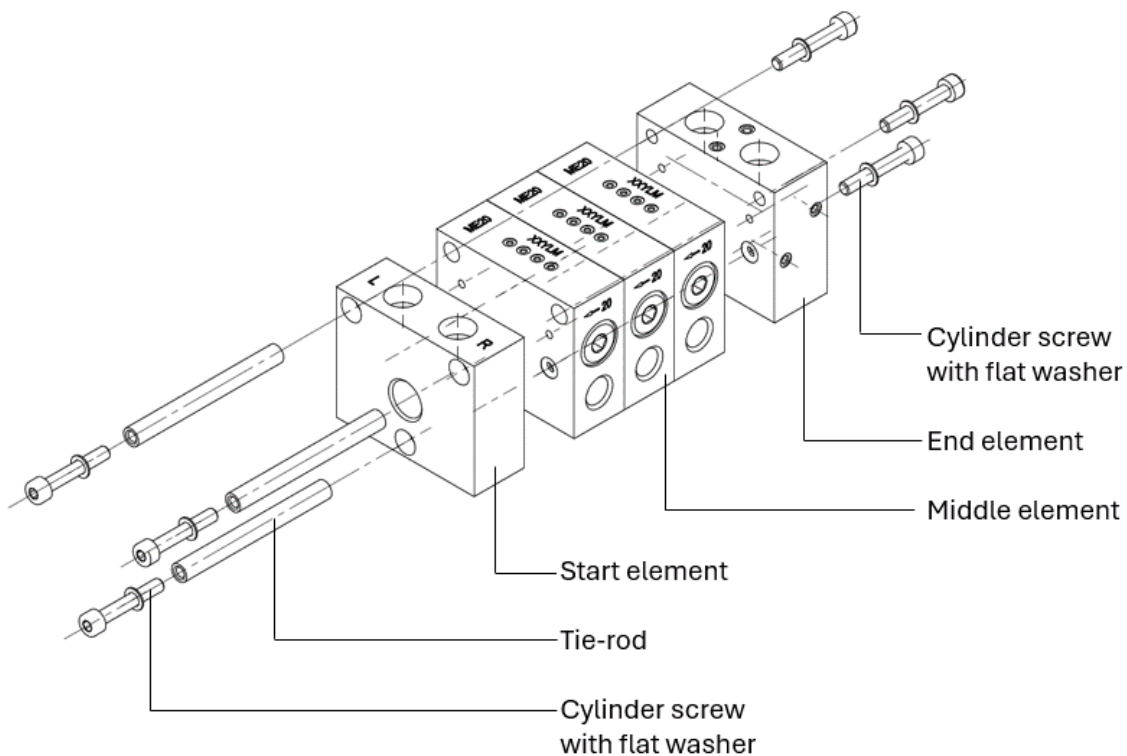

10.1 Divider elements

Divider elements	Dosing- volume/ Stroke / Output	Part no. Standard	Part no. with indication pin		Part no. with divider monitoring sensor	
			left	right	left	right
Start element SE	-	15010088	-	-	-	-
SV Start element SE for solenoid valve	-	15010087	-	-	-	-
Middle element ME-08	0,08 cm ³	15010089	-	-	-	-
Middle element ME-12	0,12 cm ³	15010090	-	-	-	-
Middle element ME-16	0,16 cm ³	15010091	-	-	-	-
Middle element ME-20	0,20 cm ³	15010092	15010096	15010524	15010232	15010706
Middle element ME-24	0,24 cm ³	15010093	15010097	15010612	15010233	15010707
Middle element ME-30	0,30 cm ³	15010094	15010098	15010613	15010234	15010708
Middle element ME-40	0,40 cm ³	15010095	15010099	15010614	15010235	15010709
End element EE	-	15010100	-	-	-	-

* all ME and EE include incl. o-ring set

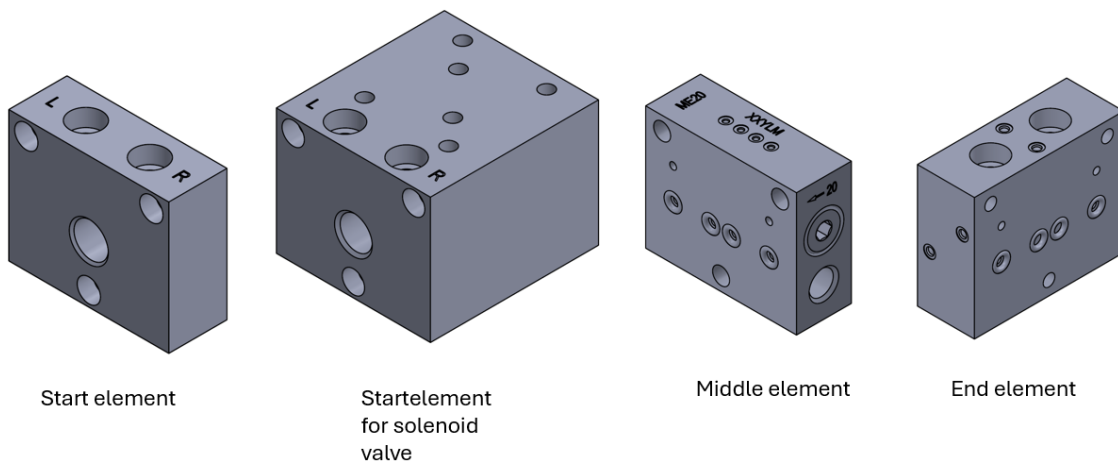

10.2 Tie rods

The disc construction of the divider allows it to be adapted to the respective operating conditions at any time. It can be lengthened or shortened accordingly by adding or removing middle elements. The following tie rods are in our delivery program.

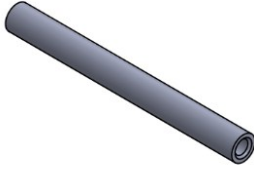

JPQ6 Divider (Standard)	JPQ6 Verteiler (SV) (with solenoid valve)	Length	Part number
JPQ6 3/X	-	58	15010285
JPQ6 4/X	-	78	15010286
JPQ6 5/X	JPQ6 3/X(SV)	98	15010287
JPQ6 6/X	JPQ6 4/X(SV)	118	15010288
JPQ6 7/X	JPQ6 5/X(SV)	138	15010289
JPQ6 8/X	JPQ6 6/X(SV)	158	15010290
JPQ6 9/X	JPQ6 7/X(SV)	178	15010291
JPQ6 10/X	JPQ6 8/X(SV)	198	15010292
	JPQ6 9/X(SV)	218	15010625
	JPQ6 10/X(SV)	238	15010626

	Part number
Hexagon socket head cap screw- DIN_EN_ISO_4762-M4x25-10.9-ST-Zn	15010283
Flat washer-DIN 125 Form A-D4,3-(M4)-ST-Zn	15010284

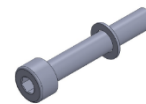

The appropriate cylinder head screws with flat washers for assembly must be ordered separately.



Note:

For the correct assembly of the distributor, three tie rods and six hexagon socket head cap screws with flat washers are required.

The tie rods must be tightened with a torque of 5 Nm

10.3 Bridge

The function of the bridge with or without outlet of the JPQ6 divider is to achieve a combined flow rate by external blinding the outlets on the same side of 2 adjacent elements.

The sealing screw of the element can be taken out or kept depends on the configuration.

	Part number
Kit-Divider bridge-JPQ6-without outlet-without non return valve	15010315
Kit-Divider bridge-JPQ6-with outlet-without non return valve	15010560

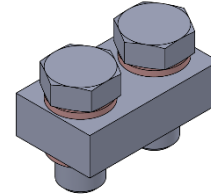

10.4 Screw plug for divider outlet

The function of the screw plug for the divider outlet is to transfer the flow rate to the opposite outlet. The dosing volume on the closed side now exits at the opposite outlet, which doubles the dosing volume on the open outlet.



Install the screw plug with a tightening torque of 19 ± 1 Nm.

	Part number
Screw plug-G1/8-DK-ST-ZnNi	15010526

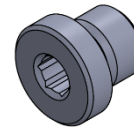

10.5 Divider Accessories

10.5.1 Solenoid valve

A solenoid valve with a special Start element can optionally be installed.

When using a solenoid valve, the volume flow to the progressive dividers can be controlled time-dependently.

Technical data:

Solenoid valve	15010118
Max. operating pressure:	400 bar
Max. output quantity:	15 l / min
Directional seated valve	2 / 2 directional
Connection	for panel fitting
Operating voltage	24 V DC
Actuation	electrical
Switching function:	2/2-way opener
Protection Type:	IP 65

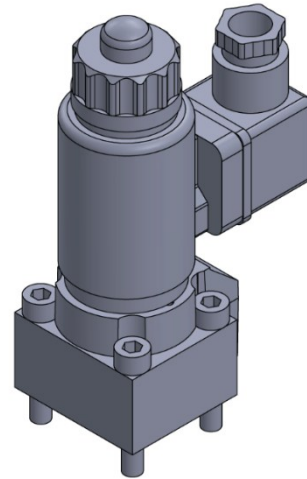

Circuit symbol:

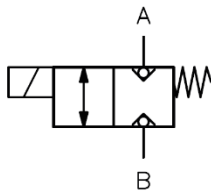

Connection diagram:



When installing a solenoid valve on the progressive divider, pay attention to the installation space!

10.5.2 Divider monitoring - Sensor

The progressive divider JPQ6 can be monitored by means of a sensor.

A sensor can be attached to the middle elements ME-20, ME-24, ME-30 and ME-40 are delivered pre-assembled. The standard mounting position of the proximity switch is on the right side.

A subsequent attachment of a sensor to an existing middle element is not possible.

The piston movement causes the pin to approach the proximity switch and trigger a signal and send the signal to the lubrication pump control unit or PLC. If the divider blocks, the control unit detects that no signals are being sent via the sensor.

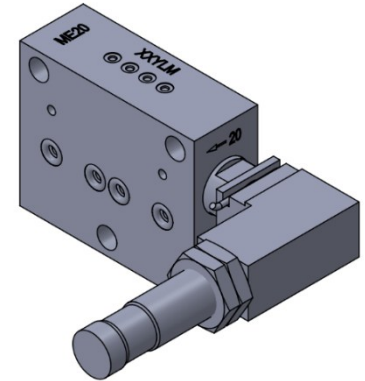

PNP: switching output NO (+).
Standard for ALPB, ALP81 and ALPE lubrication pumps

Technical data:

Sensor divider monitoring complete with housing	15010316
Working principle:	inductive
Thread of sensor:	M12x1
Thread of the connecting plug:	M12x1
Switching output:	PNP
Switch function:	Normally open
Operating current I _e :	200 mA
Operating voltage U _B :	5 to 26 V DC
Temperature Range:	- 40 °C to + 85 °C
Visual display:	Multi-hole LED, yellow
Housing material:	Brass, white bronze coated
Protection Type:	IP65 / IP66 / IP67 / IP68
Approval/Confirmity:	cULus Listed, General Purpose, Class 2 Power Source

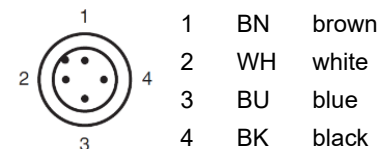
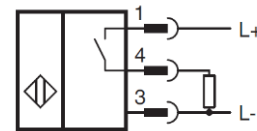

When installing a sensor on the progressive divider, pay attention to the installation space!



Install the divider monitoring sensor with a tightening torque of max. 10 Nm.

The part number for the sensor includes the housing.



The connection cable between the monitoring sensor and the lubrication pump is **NOT** included in the scope of delivery!

For information about suitable cables, check „Divider monitoring – cables“.

10.5.3 Divider monitoring - cables



The connecting cable between the sensor and the lubrication pump must be ordered separately.

Technical data:

Cable-250V AC/DC-socket M12x1-10m-3P-3x0,34	15010317
Construction type (Connector):	M12x1
Connection:	Socket
Style:	straight
Locking:	Screw connection
Number of cores x Core cross section:	3 x 0,34 mm ²
Length:	10 m
Operating voltage U _B :	max. 250 VAC/DC
Operating current I _B :	max. 4 A
Approval/Conformity:	cULus Listed, General Purpose, Class 2 Power Source

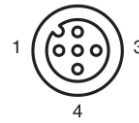

1	BN	brown
3	BU	blue
4	BK	black

11 Working principle

11.1 General

The progressive piston divider is a divider with a hydraulic sequence control, the pistons of which are controlled by the supplied lubricant in such a way that the lubricant inevitably and sequentially emerges from the individual outlets. If there is a disruption in the lubricant flow, e.g. if the lubrication line or lubrication points are blocked, the divider blocks.

This fault is used for divider monitoring. With hand-operated pumps, a blockage creates an almost insurmountable back pressure. For automatic pumps such as the electric pump ALP81 or ALPB, the lubricant escapes from the safety valve.

The progressive divider JPQ6 is manufactured in a variable disc design, which offers the advantage that the divider can be configured as desired depending on the dosage quantity of the lubrication points. This disc design also makes it possible to assemble a progressive divider made up of individual divider elements with different dosages per piston stroke.

The difference in dosage per piston stroke is caused by different piston diameters. For the progressive divider to function correctly, at least three pistons are required, i.e. at least three middle elements required.

The JPQ6 progressive divider consists of any 3 to 10 middle elements, a start and an end element.

We call the first element in the direction of the lubricant supply the starting element and the last in the row the end element.

Each element has a maximum of 2 exits, which are mounted horizontally on the side of the elements. In order to achieve the exact metering volume of different lubrication points, in some cases it is necessary to bridge the outputs of the divider internally or externally and to combine outputs.

An element can be bridged internally by installing a sealing screw.

Example:

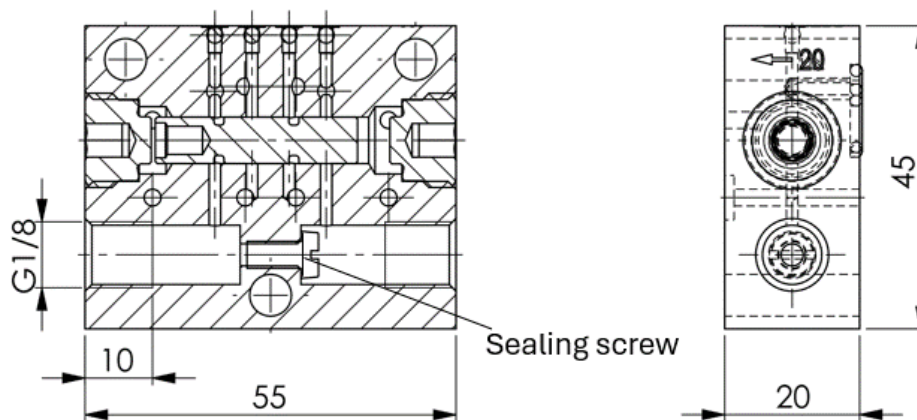

In this way, the dosage quantities of the individual divider elements can always be dosed appropriately for each lubrication point.



During the assembly of a distributor, two O-rings must be removed from the first middle element after the start element for correct functionality.

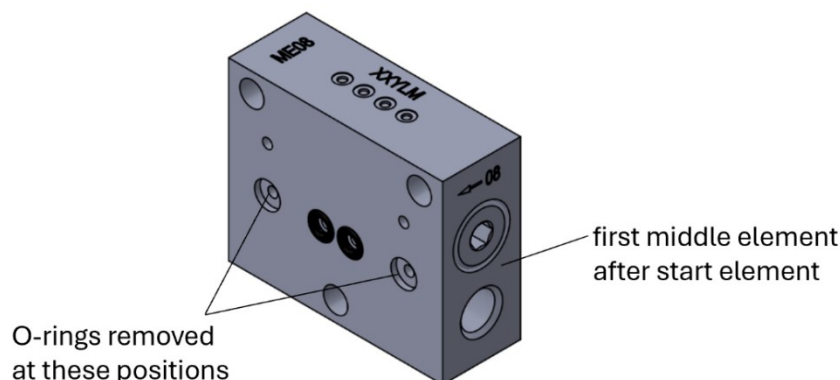

An arrow and the dosage number are stamped on the sides of the individual elements.
The output associated with each element is always located at the next element in the direction of the starting element.

By supplying the lubricant into the progressive divider, the individual pistons in the elements are gradually pushed into their stop positions and at the same time the lubricant located under the piston is pressed out of the outlets. This function is repeated as long as the progressive divider is supplied with lubricant.

All connected lubrication points are supplied with lubricant when a divider circulation is completed during operation. To do this, all pistons must have been moved from the initial to the final position and back again.

The progressive divider can be equipped with divider monitoring (signal pin or a contactless switch).

In progressive dividers with divider monitoring, the corresponding piston is provided with a pin that moves together with the piston and visualizes the circulation of the distributor (optical pin display) or carries out the contactless (inductive) switching of the control circuit.

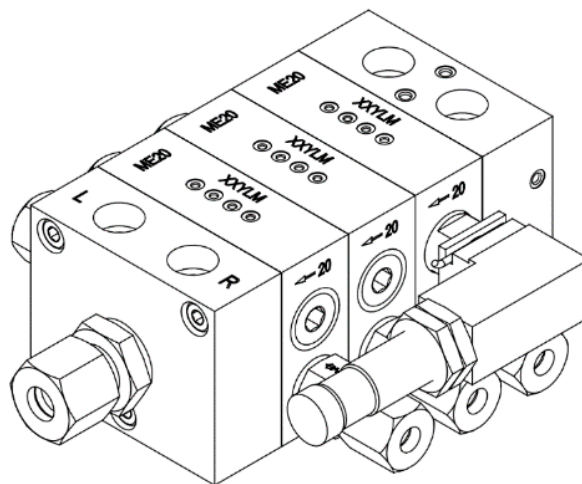

11.2 Operating principle

The progressive divider conveys the dosing volume from each divider element in a predetermined sequence to the respective subsequent middle element.

There is a deviation from this conveying sequence in the case of the middle element, which is positioned directly behind the start element. The dosing volume generated in this element is diverted internally within the progressive divider and discharged at the middle element, which is installed directly in front of the end element.

Example 1: Overview

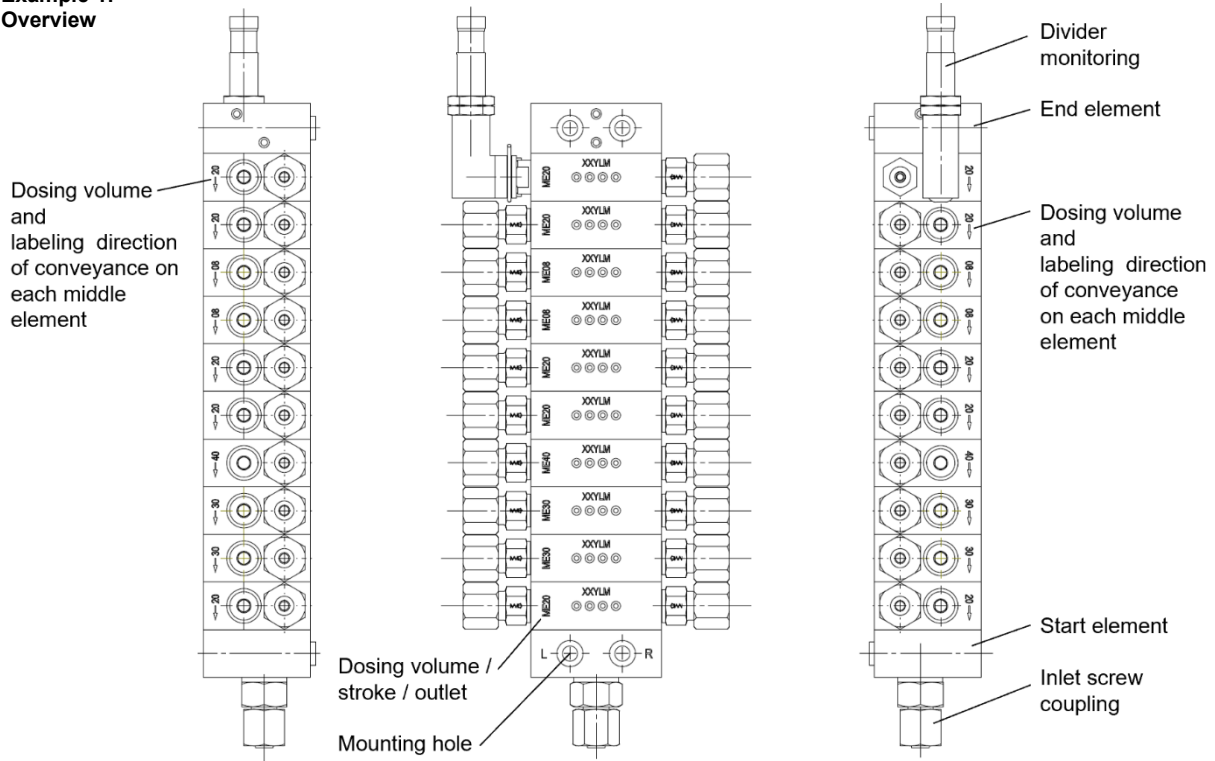

Dosing volume at the divider outlets:

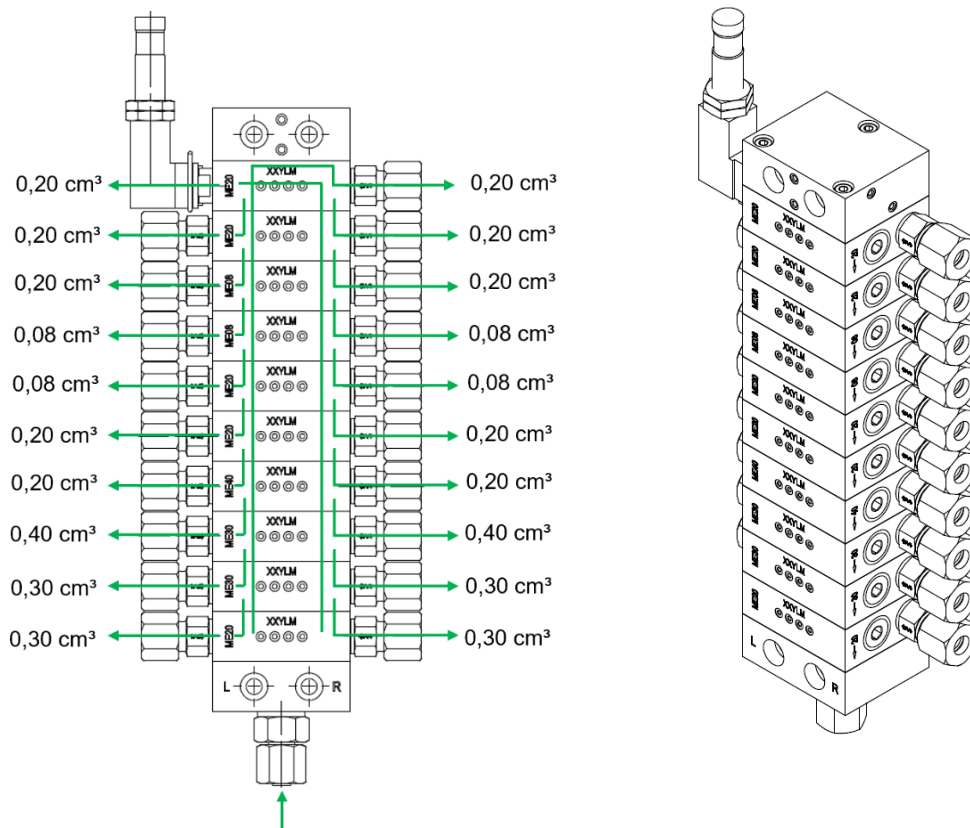

Example 2:
Overview

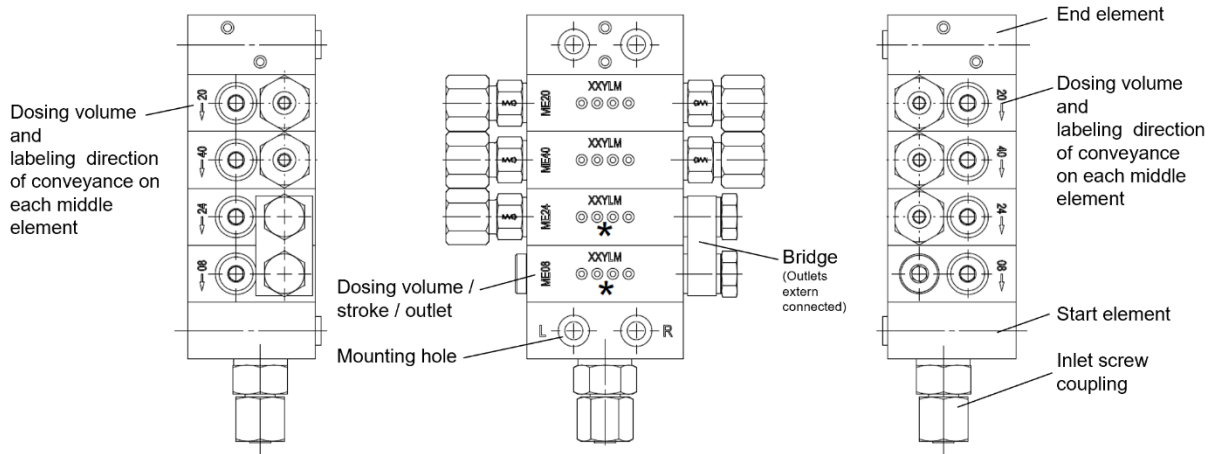

* Indicates center elements without sealing screws
(Outlets are internally connected)

Dosing volume at the divider outlets:

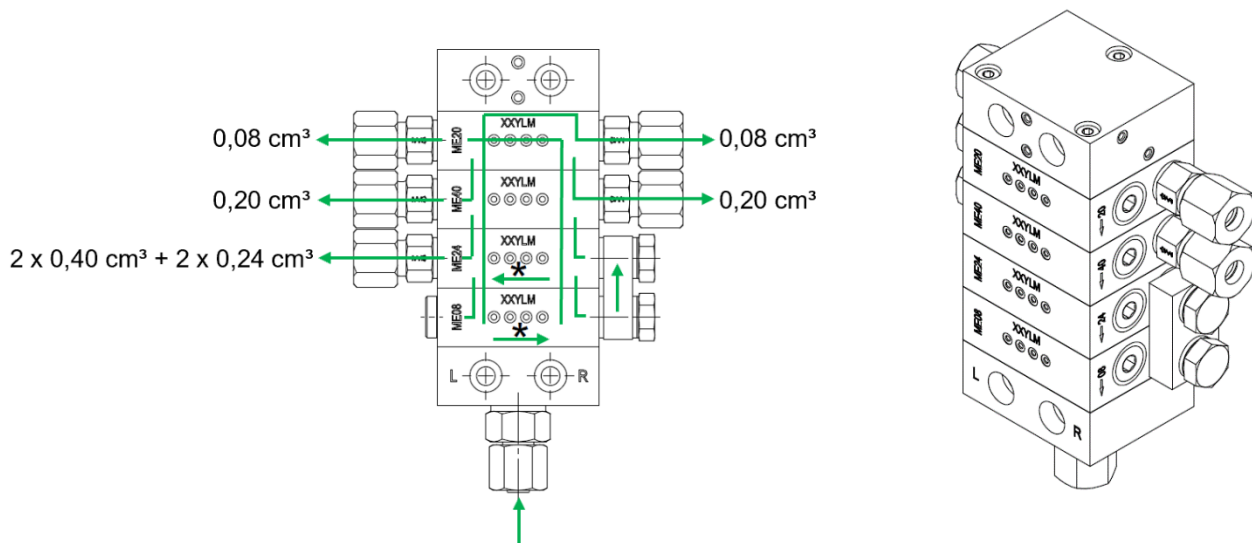

12 Commissioning / Assembly

The JPQ6 progressive divider can be mounted in any position on a flat surface.

We recommend filling the lubrication hoses with lubricant before assembly, this will vent the system and shorten the time for commissioning.

During installation, ensure that the hoses are clean, i.e. that the pipes are free of contamination. For continuous operation, we recommend checking the tightness of the lubrication circuit and the connection to the progressive divider once a month.

Please adhere to the technical specifications provided in the manual and do not exceed the specified limits. Improper use is strictly prohibited. Only use lubricants intended for this purpose. Make sure to use the product exclusively within its designated area of use.

There are four mounting holes $\varnothing 6,4$ mm on the progressive divider for fastening. Please use the distance sleeves included in the scope of delivery. Mount the progressive divider at the planned position with the appropriate torque according to the lubrication plan.

An outlet fitting (with non-return valve) or sealing screw must be installed on each divider outlet.

Start the lubrication pump until lubricant comes out without bubbles at all outputs of the progressive divider. Connect the progressive divider properly with lubrication lines to the intended secondary dividers or lubrication points.

Make sure that all lubrication lines are installed correctly.



During operation, ensure that there is sufficient lubricant in the lubrication pump.



Please note the applicable documents!

13 Troubleshooting

Fault	Possible Cause	Solution
Lubrication points get no or insufficient lubricant	Lubrication pump is empty	Refill lubricant
	Clogged or broken lubrication hose	Replace lubrication hose
	Unsuitable lubricant	Replace lubricant
	Unsuitable or defective outlet fittings (non-return valve) at the divider outlets	Check outlet fittings
	Blockage before the inlet of the main divider	Disconnect the hose from the pump to the main divider and check whether lubricant is leaking from the hose. If no lubricant is dispensed, the defect is from the hose to the main divider or the grease lubrication pump.
	Blockage on main divider	Disconnect the hose from the main divider to the secondary divider individually and check whether lubricant is leaking at the outlet of the main divider. If no lubricant is dispensed, the cause is from the main divider or the hose. Clean / replace the main divider if necessary.
	Blockage on secondary divider	Disconnect the hose from the secondary divider to the lubrication point individually and check whether lubricant is leaking at the outlet of the secondary divider. If no lubricant is dispensed, the cause is from the secondary divider or the hose. Clean / replace the secondary divider if necessary.
	Blockage of a lubrication point	Disconnect the hose from the secondary divider to the lubrication point individually and check whether lubricant is leaking at the outlet of the secondary divider. If lubricant is dispensed, the cause is from the lubrication point. Clean / replace the grease nipple if necessary.
A lubricant point gets too much or not enough lubricant	Incorrect pump setting	Check the pump working and pause time and adjust if necessary.



To check, the grease lubrication pump must be in operation and several lubrication cycles must have run so that the main dividers and any secondary dividers are sufficiently supplied with lubricant.